

Gas hob

# INSTRUCTION BOOKLET

Please read this instruction booklet before using the appliance

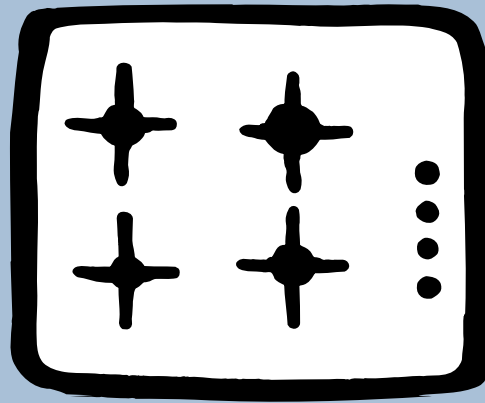

*Mod. EGG 689*

# Important Safety Information



You **MUST** read these warnings carefully before installing or using the hob. If you need assistance, contact our Customer Care Department on 08705 950950

## Installation

- This hob must be installed by qualified personnel, according to the manufacturer's instructions and to the relevant British Standards.
- Any gas installation must be carried out by a registered CORGI installer.
- Remove all packaging before using the hob.
- Ensure that the gas and electrical supply complies with the type stated on the rating plate, located near the gas supply pipe.
- Do not attempt to modify the hob in any way.

## Child Safety

- This hob is designed to be operated by adults. Do not allow children to play near or with the hob.
- The hob gets hot when it is in use.
- Children should be kept away until it has cooled.
- Children can also injure themselves by pulling pans or pots off the hob.

## During Use

- This hob is intended for domestic cooking only. It is not designed for commercial or industrial purposes.
- When in use a gas cooking appliance will produce heat and moisture in the room in which it has been installed. Ensure there is a continuous air supply, keeping air vents in good condition or installing a cooker hood with a venting hose.
- When using the hob for a long period of time, the ventilation should be improved, by opening a window or increasing the extractor speed.
- Do not use this hob if it is in contact with water. Do not operate the hob with wet hands.
- Ensure the control knobs are in the 'OFF' position when not in use.
- When using other electrical appliances, ensure the cable does not come into contact with the hot surfaces of the cooking appliance.
- Unstable or misshapen pans should not be used on the hob as unstable pans can cause an accident by tipping or spillage.
- Never leave the hob unattended when cooking with oil and fats.
- Never use plastic or aluminium foil dishes on the hob.
- Perishable food, plastic items and aerosols may be affected by heat and should not be stored above or below the hob unit.

## Service

- This hob should only be repaired or serviced by an authorised Service Engineer and only genuine approved spare parts should be used.

## Environmental Information

- After installation, please dispose of the packaging with due regard to safety and the environment.
- When disposing of an old appliance, make it unusable, by cutting off the cable.

**Keep this instruction book for future reference and ensure it is passed on to any new owner.**

## Guide to Use the instructions

The following symbols will be found in the text to guide you throughout the Instructions:



Safety Instructions



Step by step instructions for an operation



Hints and Tips



Environmental information



This appliance complies with the following **E.E.C. Directives:**

- \* **73/23 - 90/683** (Low Voltage Directive);
- \* **93/68** (General Directives);
- \* **89/336** (Electromagnetical Compatibility Directive);
- \* **90/396** (Gas Appliances), and subsequent modifications

# Contents

## For the User

Important Safety Information	2
Description of the Hob	3
Operation	4
Maintenance and Cleaning	4
Something Not Working?	5
Service and Spare Parts	5
Guarantee Conditions	6

## For the Installer

Instructions for the Installer	7
Important safety requirements	8
Installation	8
Building In	9
Electrical connections	10
Wiring Diagram	11
Fault Finding	11
Commissioning	13
Conversion from Natural Gas to LPG	14

# Description of the Hob

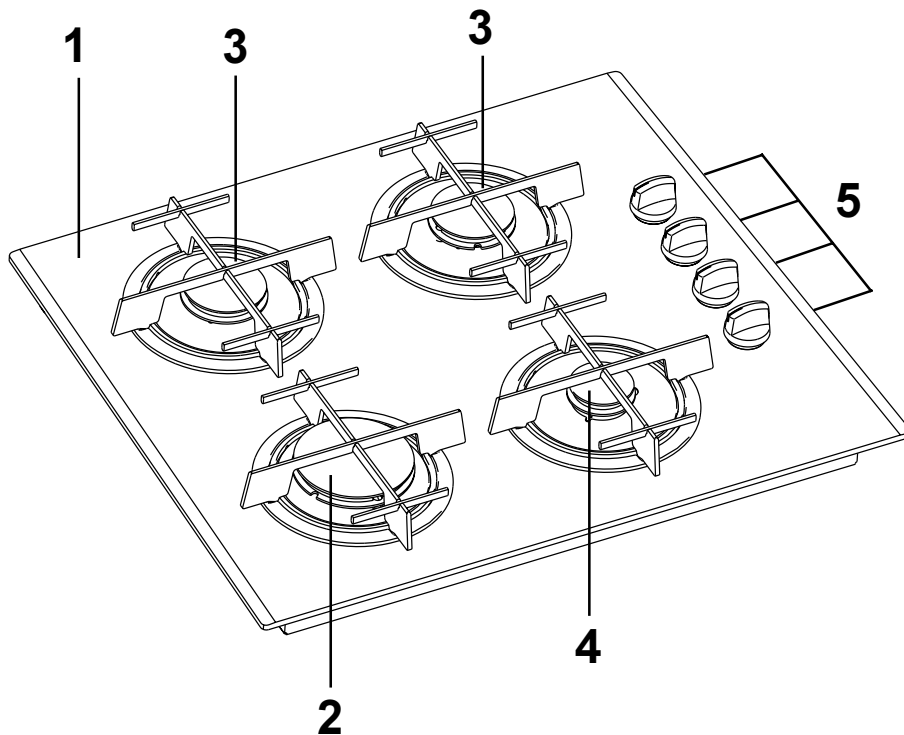

1. Hob top
2. Rapid Burner
3. Semi-rapid Burner
4. Auxiliary Burner
5. Control knobs

# Operation

## Hob burners

 To light a burner:

- push in the relevant control and turn it to maximum position;
- then adjust the flame as required.
- If the burner does not ignite, turn the control knob to zero, and try again.



If you use a saucepan which is smaller than the recommended size, the flame will spread beyond the bottom of the vessel, causing the handle to overheat.

**Take care when frying food in hot oil or fat, as the overheated splashes could easily ignite.**

As soon as a liquid starts boiling, turn down the flame so that it will barely keep the liquid simmering.

To ensure maximum burner efficiency, you should only use pots and pans with a flat bottom fitting the size of the burner used (see table).

Burner	minimum diameter	maximum diameter
Large (rapid)	160 mm.	240 mm.
Medium (semi-rapid)	120 mm.	220 mm.
Small (auxiliary)	80 mm.	160 mm.



If the control knobs become difficult to turn, please contact your local Electrolux Service Centre.

# Maintenance and Cleaning



Before any maintenance or cleaning can be carried out, you must **DISCONNECT** the hob from the electricity supply.



The hob is best cleaned whilst it is still warm, as spillage can be removed more easily than if it is left to cool.

## The Hob Top

Regularly wipe over the hob top and the aluminium frame using a soft cloth well wrung out in warm water to which a little washing up liquid has been added. Avoid the use of the following:

- household detergent and bleaches;
- impregnated pads unsuitable for non-stick saucepans;
- steel wool pads;
- bath/sink stain removers.

Should the hob top become heavily soiled, it is recommended that a cleaning product such as Hob Brite or Bar Keepers Friend is used.

## Pan Supports

The pan supports are dishwasher proof. If washing them by hand, take care when drying them as the enamelling process occasionally leaves rough edges.

If necessary, remove stubborn stains using a paste cleaner. Never use steel wool pads or acids.

## The Burners

The burner caps and crowns can be removed for cleaning. Wash the burner caps and crowns using hot soapy water, and remove marks with a mild paste cleaner. A well moistened soap impregnated steel wool pad can be used with caution, if the marks are particularly difficult to remove.

After cleaning, be sure to wipe dry with a soft cloth.

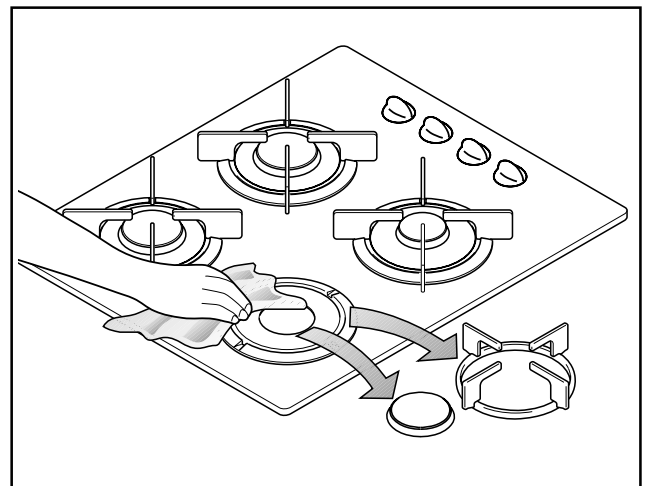

# Something Not Working?

If the hob is not working correctly, please carry out the following checks before contacting your local Service Force Centre.

**IMPORTANT:** If you call out an engineer to a fault listed below, or to repair a fault caused by incorrect use or installation, a charge will be made even if the appliance is under guarantee.

SYMPTOM	SOLUTION
■ There is no spark when lighting the gas	◆ Check that the unit is plugged in and the electrical supply is switched on ◆ Check that the RCCB has not tripped (if fitted) ◆ Check the mains fuse has not blown ◆ Check the burner cap and crown have been replaced correctly, e.g. after cleaning.
■ The gas ring burns unevenly	◆ Check the main jet is not blocked and the burner crown is clear of food particles. ◆ Check the burner cap and crown have been replaced correctly, e.g. after cleaning.

If after all these checks, your hob still does not operate correctly, contact your local Service Force Centre.

Please note that it will be necessary to provide proof of purchase for any in-guarantee service calls.

**In-guarantee customers should ensure that the above checks have been made as the engineer will make a charge if the fault is not a mechanical or electrical breakdown.**

## Service and Spare Parts



In the event of your appliance requiring service, or if you wish to purchase spare parts, please contact your local Electrolux Service Force Centre by telephoning:

**0870 5 929929**

Your telephone call will be automatically routed to the Service Force Centre covering your post code area. For the address of your local Service Force Centre and further information about Service Force, please visit the website at [www.serviceforce.co.uk](http://www.serviceforce.co.uk)

Before calling out an engineer, please ensure you have read the details under the heading "Something Not Working."

When you contact the Service Force Centre you will need to give the following details:

1. Your name, address and post code
2. Your telephone number
3. Clear and concise details of the fault
4. The model and serial number of the appliance (found on the rating plate)
5. The purchase date

# Customer Care Department

For general enquiries concerning your Electrolux appliance or for further information on Electrolux products, please contact our Customer Care Department by letter or telephone at the address below or visit our website at [www.electrolux.co.uk](http://www.electrolux.co.uk)

## Customer Care Department

**ELECTROLUX**  
55-77 High Street  
Slough  
Berkshire  
SL1 1DZ  
Tel. 08705 950950 (\*)

\* calls to this number may be recorded for training purposes.

# Guarantee Conditions

## Electrolux Guarantee conditions

We, Electrolux, undertake that if, within 12 months of the date of the purchase, this Electrolux appliance or any part thereof is proved to be defective by any reason only of faulty workmanship or materials, we will, at our option, repair or replace the same **FREE OF ANY CHARGE** for labour, materials or carriage on condition that:

- \* The appliance has been correctly installed and used only on the gas and electricity supply stated on the rating plate.
- \* The appliance has been used for normal domestic purpose only, and in accordance with the manufacturer's instructions.
- \* The appliance has not been serviced, maintained, repaired, taken apart or tampered with by any person not authorised by us.
- \* All service work under this guarantee must be undertaken by a Electrolux Service Centre.
- \* Any appliance or defective part replaced shall become the Company's property.
- \* This guarantee is in addition to your statutory and other legal rights.

Home visits are made between **8.30am and 5.30pm** Monday to Friday. Visits may be available outside these hours, in which case a **premium** will be charged.

## Exclusions

**This guarantee does not cover:**

- \* Damage or calls resulting from transportation, improper use or neglect, the replacement of any light bulbs or removable parts of glass or plastic.
- \* Costs incurred for calls to put right an appliance which is improperly installed or calls to appliance outside the United Kingdom.

- \* Appliances found to be in use within a commercial or similar environment, plus those which are the subject to rental agreements.
- \* Products of Electrolux manufacture which are not marketed by Electrolux.

## European Guarantee

If you should move to another country within Europe then your guarantee moves with you to your new home subject to the following qualifications:

- \* The guarantee starts from the date you first purchased your product.
- \* The guarantee is for the same period and to the same extent for labour and parts as exist in the new country of use for this brand or range of products.
- \* This guarantee relates to you and cannot be transferred to another user.
- \* Your new home is within the European Community (EC) or European Free Trade Area.
- \* The product is installed and used in accordance with our instructions and is only used domestically, i.e. a normal household
- \* The product is installed taking into account regulations in your new country.

Before you move, please contact your nearest Customer Care centre, listed below, to give them details of your new home. They will then ensure that the local Service Organisation is aware of your move and able to look after you and your appliances.

France	Senlis	+33 (0) 3 44 62 20 13
Germany	Nürnberg	+49 (0) 800 234 7378
Italy	Pordenone	+39 (0) 800 117511
Sweden	Stockholm	+46 (0) 20 78 77 50
UK	Slough	+44 (0)1753 219898

# Instructions for the Installer

## Engineers technical data

### Overall dimensions

Width: 580 mm.  
Depth: 510 mm.

### Ignition HT Spark

Spark Generator Ispra Control's BF 50046  
230-240V 0.6 YA T 120  
Spark Gap Fixed

### Cut out dimensions

Width: 550 mm.  
Depth: 470 mm.

### Semi-rapid Burner

Heat Input 1.9 kW (6483 BTU/HR)

### Rapid Burner

Heat Input 2.9 kW Natural Gas (9895 BTU/HR)  
2.7 kW L.P.G. (9212 BTU/HR)

## Supply connections

### Gas:

R 1/2 inch (1/2 inch male) Rear right hand corner

### Auxiliary Burner

Heat Input 1.0 kW (3412 BTU/HR)

### Electric:

230-240V 50Hz supply, 3 core flexible cable with non rewirable plug fitted with a 3 amp cartridge fuse.

TYPE OF GAS	CHARACTERISTICS	BURNER	RAPID (large)		SEMI-RAPID (medium)		AUXILIARY (small)	
		POSITION	MAX	MIN	MAX	MIN	MAX	MIN
NATURAL GAS 20 mbar	VALUE = 37.78 MJ/m <sup>3</sup> Ws - 50.7 MJ/m <sup>3</sup>	NOMINAL THERMAL POWER kW	2.9	0.65	1.9	0.45	1.0	0.33
		NOMINAL FLOW RATE m <sup>3</sup> /h	0.276	0.062	0.181	0.043	0.095	0.031
		NOZZLE REFERENCE 1/100 mm	119	Adjust.	96	Adjust.	70	Adjust.
LPG GAS 28-30/37 mbar	VALUE = 49.92 MJ/Kg	NOMINAL THERMAL POWER kW	2.7	0.65	1.9	0.45	1.0	0.33
		NOMINAL FLOW RATE g/h	195	46.8	137	32.4	72	23.8
		NOZZLE REFERENCE 1/100 mm	86	40	71	32	50	28

Burner	Dia. Tap By-pass 1/100 mm
Auxiliary	28
Semi-rapid	32
Rapid	40
Aeration adjustment	none

APPLIANCE CLASS: 3

APPLIANCE CATEGORY: I12H3+

APPLIANCE GAS SUPPLY: Natural gas G20 / 20mbar

# Important safety requirements

This hob must be installed in accordance with the Gas Safety (Installation and Use) Regulations (Current Edition) and the IEE Wiring Regulations (Current Edition).

Detailed recommendations are contained in the following British Standards Codes Of Practice: B.S. 6172/ B.S. 5440, Part 2 and B.S. 6891 Current Editions.

The hob should not be installed in a bed sitting room with a volume of less than 20 m<sup>3</sup>. If it is installed in a room of volume less than 5 m<sup>3</sup> an air vent of effective area of 110 cm<sup>2</sup> is required. If it is installed in a room of volume between 5 m<sup>3</sup> and 10 m<sup>3</sup> an air vent of effective area of 50 cm<sup>2</sup> is required, while if the volume exceeds 11 m<sup>3</sup> no air vent is required.

However, if the room has a door which opens directly to the outside no air vent is required even if the volume is between 5 m<sup>3</sup> and 11 m<sup>3</sup>.

If there are other fuel burning appliances in the same room, B.S. 5440 Part 2 Current Edition, should be consulted to determine the requisite air vent requirements.

## Location

The hob may be located in a kitchen, a kitchen/diner or bed sitting room, but not in a bathroom, shower room or garage.

Before making the cut out in the worktop ensure that the edges of the hob that are to be near either a side or rear wall have a minimum distance of 55 mm. between the edge of the hob and the wall.

The minimum distance combustible material can be fitted above the hob is 400 mm. If it is fitted below 400 mm. a space of 50 mm. must be allowed from the edges of the hob.

The minimum distance combustible material can be fitted directly above the hob is 700 mm. A minimum distance of 100 mm. must be left between the side edges of the hob and any adjacent cabinets or walls.

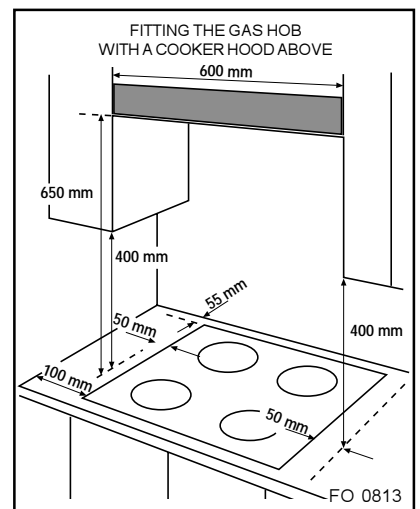
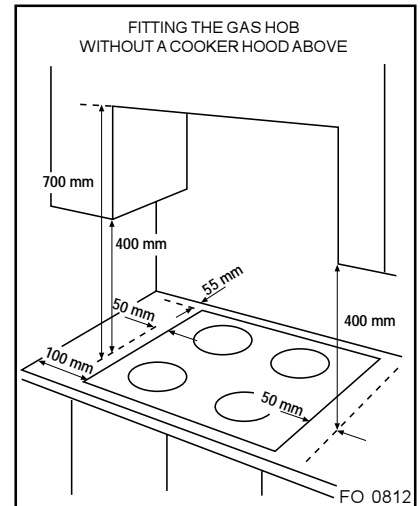

## Installation

### IMPORTANT



This hob must be installed by **qualified personnel** to the relevant British Standards.

Any gas installation must be carried out by a registered CORGI installer.

The manufacturer will not accept liability, should the above instructions or any of the other safety instructions incorporated in this book be ignored.

### WHEN THE HOB IS FIRST INSTALLED



Once the hob has been installed, it is important to remove any protective materials, which were put on in the factory.

On the end of the shaft, which includes the G 1/2" threaded elbow, adjustment is fixed so that the washer is fitted between the components as shown in the diagram. Screw the parts together without using excessive force.

## Gas Connection

Connection to the gas supply should be with either rigid or semi-rigid pipe, i.e. steel or copper.

The connection should be suitable for connecting to R 1/2" (1/2 BSP male thread).

When the final connection has been made, it is essential that a thorough leak test is carried out on the hob and installation. Ensure that the main connection pipe does not exert any strain on the hob.



It is important to install the elbow correctly, with the shoulder on the end of the thread, fitted to the hob connecting pipe.

Failure to ensure the correct assembly will cause leakage of gas.

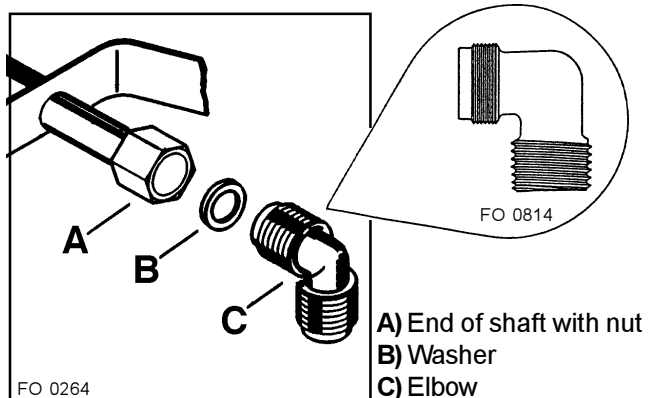



## Cut Out Size

The dimensions of the cut-out are given in the diagram.

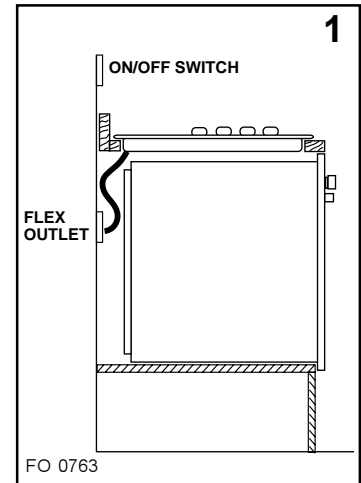
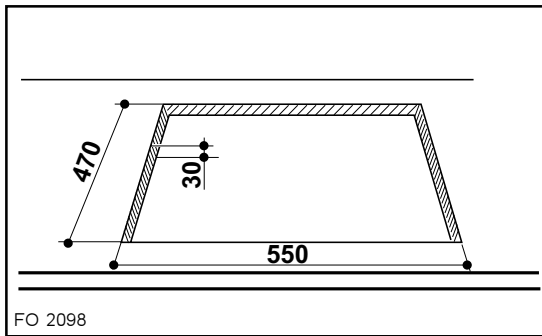

## Building In

### Building over a cupboard or drawer

If the hob is to be installed above a cupboard or drawer it will be necessary to fit a heat resistant board below the base of the hob on the underside of the work surface.

It is also recommended to carry out the electrical connection to the hob as shown in diagrams 1 and 2.

### Building over a kitchen unit with door

Proper arrangements must be taken in designing the furniture unit, in order to avoid any contact with the bottom of the hob which can be heated when it is operated. The recommended solution is shown in diagram 3.

The panel fitted under the hob ("a") should be easily removable to allow easy access if technical assistance is needed. The space behind the kitchen unit ("b") can be used for connections.

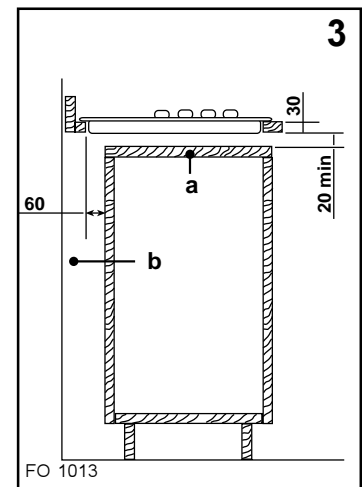
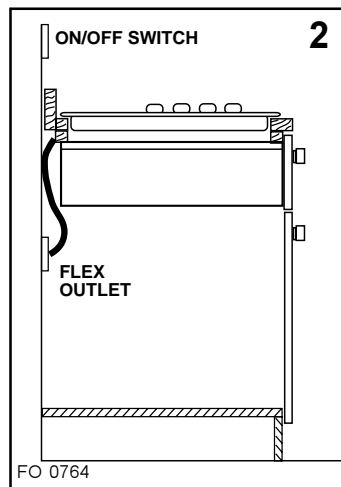

Dimensions are given in mm.

### Fitting the hob to the worktop

Before fitting the hob into the cut out, an adhesive seal must be fitted to the underside outside edge (diagram 4) of the hob. It is essential that no gaps are left in this seal in order to prevent spillage near the hob seeping into the cabinet below.

- 1) Remove the pan supports, the burners caps and crowns and turn the hob upside down, taking care the ignition candles are not damaged in this operation.
- 2) Place the sealing gasket all around the glass top edge as shown in diagram 4.
- 3) Fit the hob in the cut out and push it down until the glass top and the working top make contact, as shown in diagram 5.

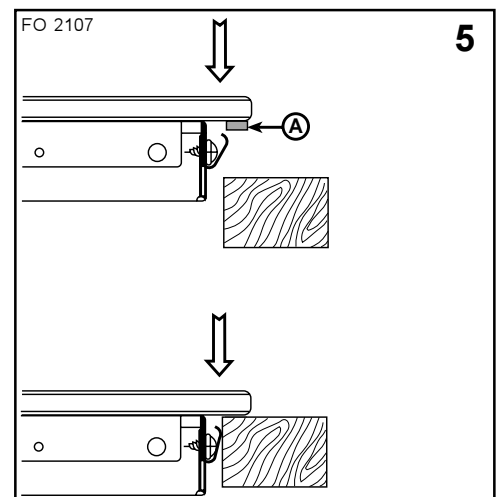
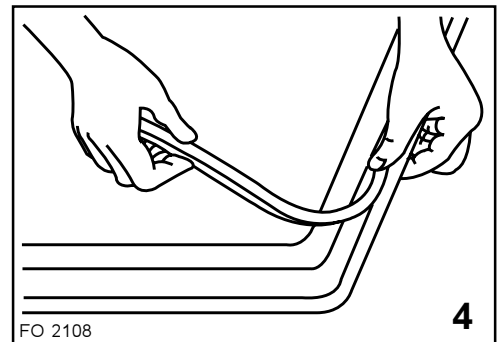

a) Sealing gasket

# Electrical connections



Any electrical work required to install this hob should be carried out by a qualified electrician or competent person, in accordance with the current regulations.



**THIS APPLIANCE MUST BE EARTHED.**

The manufacturer declines any liability should these safety measures not be observed.

**This hob is designed to be connected to a 230-240V 50Hz AC electrical supply.**

Before switching on, make sure the electricity supply voltage is the same as that indicated on the hob rating plate. The rating plate is located on the bottom of the hob. A copy is attached on the back cover of this book.

The hob is supplied with a 3 core flexible supply cord incorporating a 3amp plug fitted. In the event of having to change the fuse, a 3amp ASTA approved (BS 1362) fuse must be used.

Should the plug need to be replaced for any reason, the wires in the mains lead are coloured in accordance with the following code:

Green and Yellow - Earth  
 Blue - Neutral  
 Brown - Live



- Connect the green and yellow (earth) wire to the terminal in the plug which is marked with the letter 'E' or the earth symbol  or coloured green and yellow.
- Connect the blue (neutral) wire to the terminal in the plug which is marked with the letter 'N' or coloured black.
- Connect the brown (live) wire to the terminal in the plug which is marked with the letter 'L' or coloured red.

Upon completion there must be no cut, or stray strands of wire present and the cord clamp must be secure over the outer sheath.



**A cut off plug inserted into a 13 amp socket is a serious safety (shock) hazard. Ensure that the cut off plug is disposed of safely.**

## Permanent Connection

In the case of a permanent connection, it is necessary that you install a double pole switch between the hob and the electricity supply (mains), with a minimum gap of 3 mm. between the switch contacts and of a type suitable for the required load in compliance with the current electric regulations.

The switch must not break the yellow and green earth cable at any point.



**Ensure that the hob supply cord does not come into contact with surfaces with temperatures higher than 50 deg. C.**

## Supply cable replacement

The cable used to connect the hob to the electrical supply must comply to the specifications given below.

Min. size Cable/flex	Cable / flex type	Fuse
0.75 mm <sup>2</sup>	H05 V2V2-F (T90)	3 A

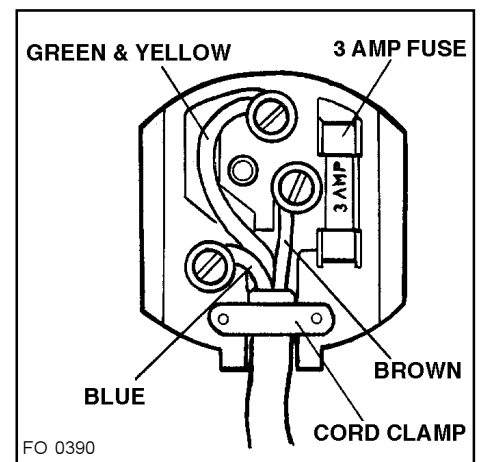

# Wiring Diagram

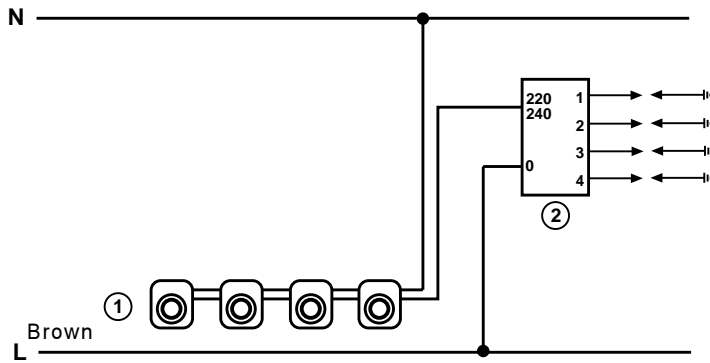

A. IGNITOR SWITCH  
B. IGNITOR UNIT

# Fault Finding

## Preliminary Electrical Systems Check

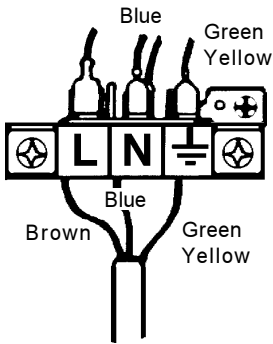

**START**  
Isolate appliance and carry out:  
**A: Earth Continuity** check.

PLUG (with cover removed)

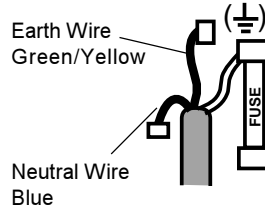

SOCKET (face view)

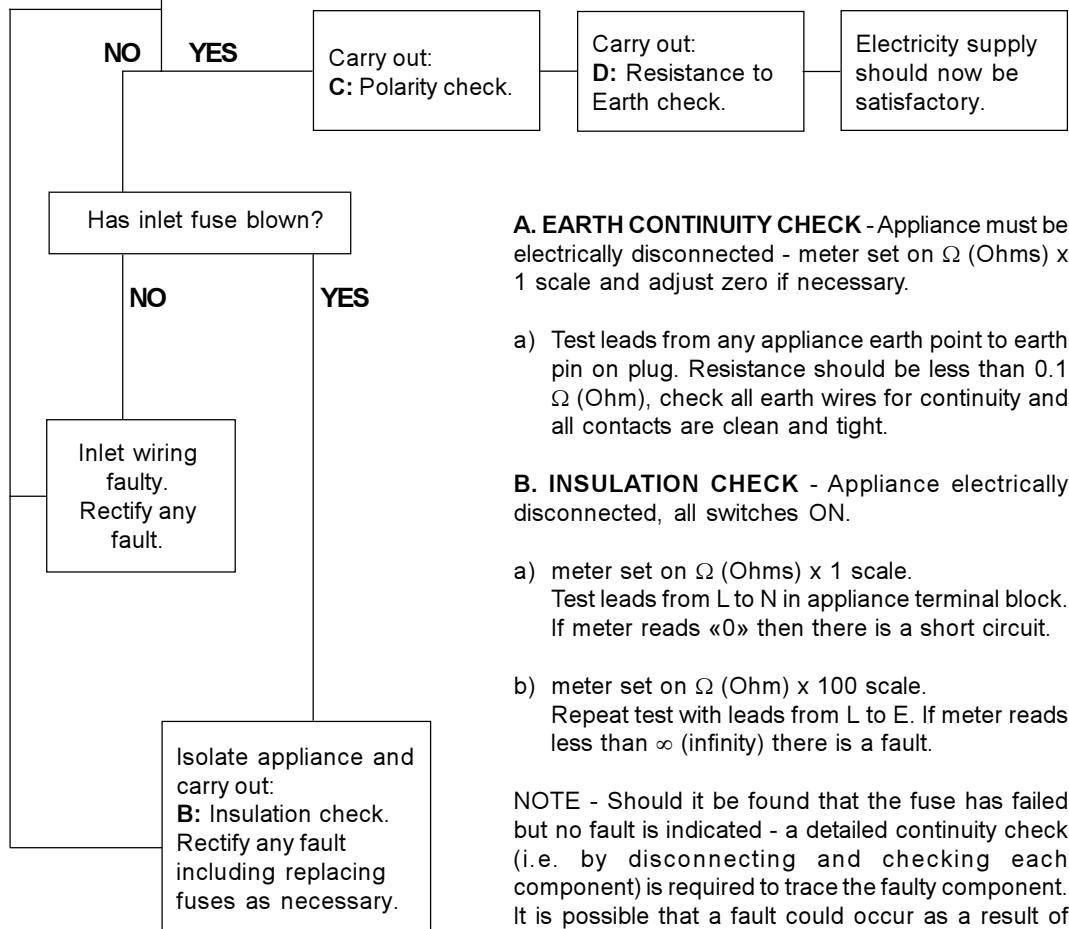
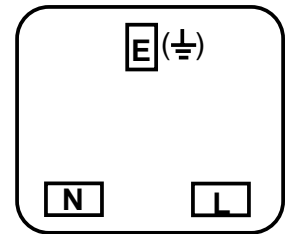

**A. EARTH CONTINUITY CHECK** - Appliance must be electrically disconnected - meter set on  $\Omega$  (Ohms) x 1 scale and adjust zero if necessary.

- a) Test leads from any appliance earth point to earth pin on plug. Resistance should be less than 0.1  $\Omega$  (Ohm), check all earth wires for continuity and all contacts are clean and tight.

**B. INSULATION CHECK** - Appliance electrically disconnected, all switches ON.

- a) meter set on  $\Omega$  (Ohms) x 1 scale. Test leads from L to N in appliance terminal block. If meter reads «0» then there is a short circuit.
- b) meter set on  $\Omega$  (Ohm) x 100 scale. Repeat test with leads from L to E. If meter reads less than  $\infty$  (infinity) there is a fault.

NOTE - Should it be found that the fuse has failed but no fault is indicated - a detailed continuity check (i.e. by disconnecting and checking each component) is required to trace the faulty component. It is possible that a fault could occur as a result of local burning/arcing but no fault could be found under test. However a detailed visual inspection should reveal evidence of burning around the fault.

# Ignition System / Gas Ignition

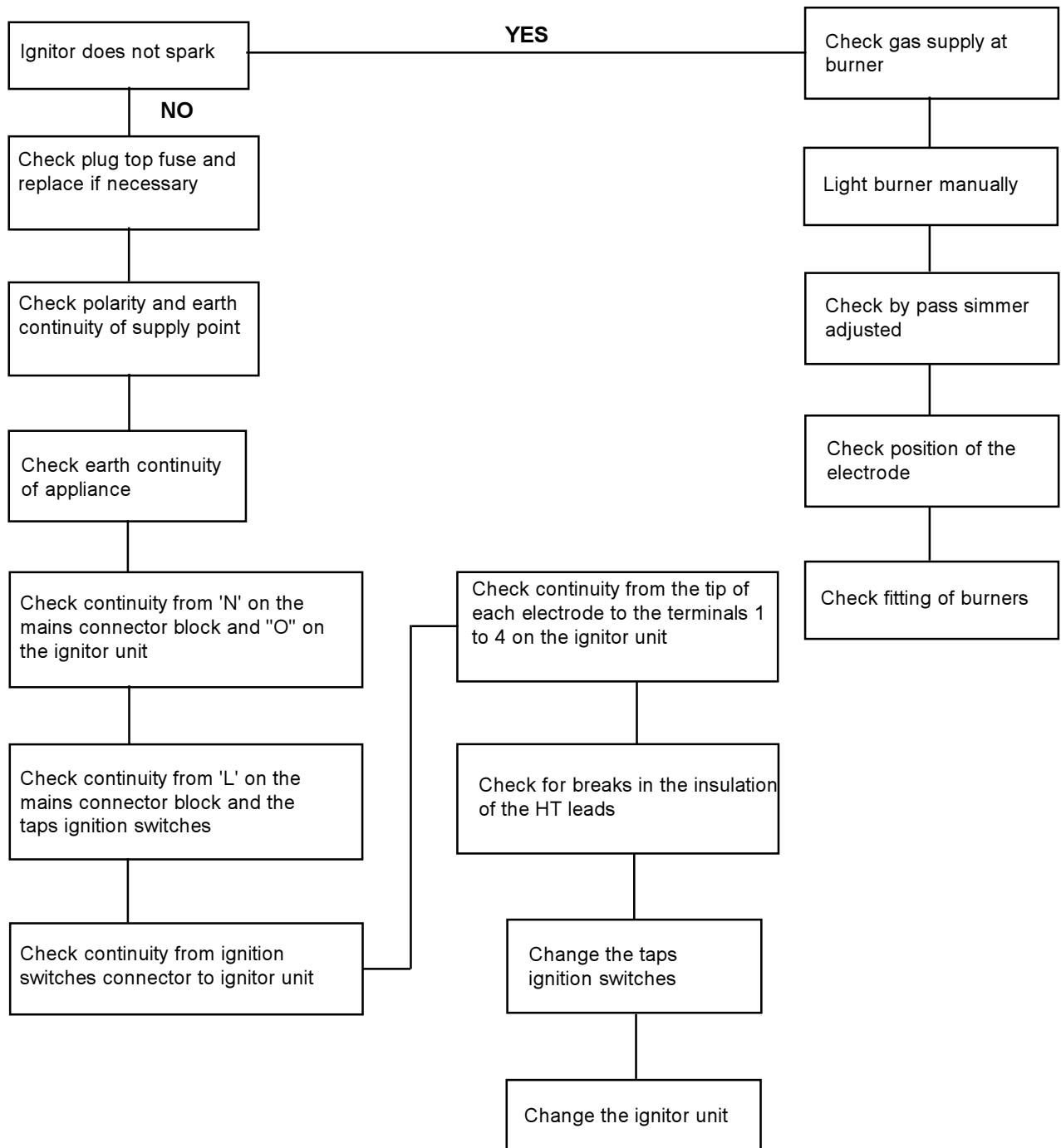

# Commissioning

When the hob has been fully installed it will be necessary to check the minimum flame setting. To do this, follow the procedure below.

- Turn the gas tap to the MAX position and ignite.
- Set the gas tap to the MIN flame position then turn the control knob from MIN to MAX several times. If the flame is unstable or is extinguished follow the procedure below.

## Procedure:

- ☞ Re-ignite the burner and set to MIN.  
Remove the control knob.  
To adjust, use a thin bladed screwdriver and turn the adjustment screw (see diagram) until the flame is steady and does not extinguish, when the knob is turned from MIN to MAX. Repeat this procedure for all burners.

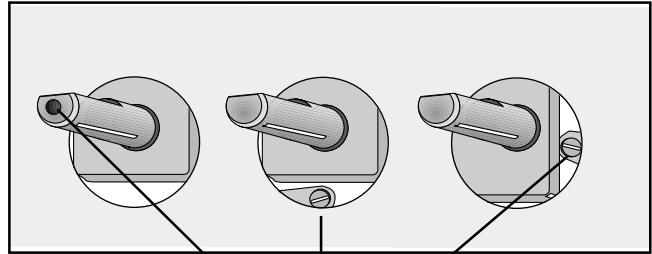

**Minimum adjustment screw**

## Pressure Testing

- ☞ Remove left hand pan support and front left burner cap and crown.  
Fit manometer tube over the injector.  
Turn on the burner gas supply and ignite another burner.  
The pressure reading should be nominally 20mbar and must be between 17 mbar and 25mbar.  
Turn off the burner supplies.

# Conversion from Natural Gas to LPG

It is important to note that this model is designed for use with natural gas but can be converted for use with butane or propane gas providing the correct injectors are fitted. The gas rate is adjusted to suit.

## Method

- Ensure that the gas taps are in the 'OFF' position
- Isolate the hob from the electrical supply
- Remove all pan supports, burner caps, rings, crowns and control knobs.
- With the aid of a 7mm box spanner the burner injectors can then be unscrewed and replaced by the appropriate LPG injectors.

## To adjust the gas rate

With the aid of a thin bladed screwdriver completely tighten down the by pass adjustment screw. Upon completion affix the replacement rating plate on the under side of the hob.

## IMPORTANT

The replacement/conversion of the gas hob should only be undertaken by a competent person.



## CUSTOMER CARE

### Electrolux

55-77 High Street  
Slough  
Berkshire, SL1 1DZ  
Tel: 08705-950950

© Electrolux plc 2003

 **The Electrolux Group.** *The world's No.1 choice.*

*The Electrolux Group is the world's largest producer of powered appliances for kitchen, cleaning and outdoor use. More than 55 million Electrolux Group products (such as refrigerators, cookers, washing machines, vacuum cleaners, chain saws and lawn mowers) are sold each year to a value of approx. USD 14 billion in more than 150 countries around the world.*