

JLBIOS60 I

built-in oven

Instruction manual

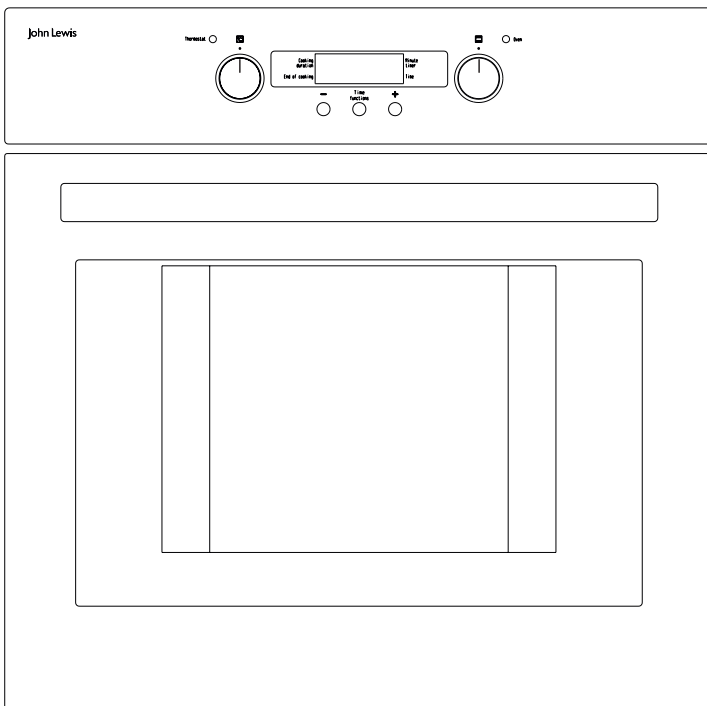

John Lewis

Important Safety Information



It is most important that this instruction manual should be retained with the appliance for future reference. Should the appliance be sold or transferred to another owner, or should you move house and leave the appliance, always ensure that the book is supplied with the appliance in order that the new owner can get to know the functioning of the appliance and the relevant warnings. These warnings have been provided in the interest of safety. You **MUST** read them carefully before use or installation by a qualified person. If you are unsure of the meanings of these warnings contact the John Lewis branch from which you purchased the appliance.

Installation

- This oven must be installed by qualified and competent personnel to the relevant National Standards.
- Refer to Installation information on pages 6 and 7.
- This oven is heavy. Take care when moving it.
- Remove all packaging, both inside and outside the oven, before using the oven.
- Do not attempt to modify the oven in any way.
- Do not leave cookware containing foodstuffs, e.g. fat or oil in or on the oven in case it is inadvertently switched ON.
- When using other electrical appliances, ensure the cable does not come into contact with the hot surfaces of the oven.

People Safety

- This oven is designed to be operated by adults. Do not allow children to play near or with the oven.
- The oven gets hot when it is in use. Children should be kept away until it has cooled.
- This appliance is not intended for use by children or other persons whose physical, sensory or mental capabilities or lack of experience and knowledge prevents them from using the appliance safely without supervision or instruction by a responsible person to ensure that they can use the appliance safely.

Use

- This oven is intended for domestic cooking only. It is not designed for commercial or industrial purposes.
- Appliances become very hot with use, and retain their heat for long periods after use. Care should be taken to avoid touching heating elements inside the oven.
- Always stand back from the oven when opening the oven door during cooking or at the end of it to allow any build up of steam or heat to release.
- Never line any part of the oven with aluminium foil.
- Do not allow heatproof cooking material, e.g. roasting bags, to come into contact with oven elements.
- Never place plastic or any other material which may melt in or on the oven.
- Do not place sealed cans or aerosols inside the oven. They may explode if they are heated.
- Do not hang towels, dishcloths or clothes from the oven or its handle.
- Do not use this oven if it is in contact with water and never operate it with wet hands.
- Take great care when heating fats and oils as they will ignite if they become too hot.
- Always use oven gloves to remove and replace food in the oven.
- Ensure that all control knobs are in the OFF position when not in use.

Maintenance and Cleaning

- Only clean this oven in accordance with the instructions.
- The oven should be kept clean at all times. A build-up of fats or other foodstuffs could result in a fire, especially in the grill pan.
- Never use steam or high pressure steam cleaners to clean the appliance.
- Always allow the oven to cool down and switch off the electrical supply before carrying out any cleaning or maintenance work.
- Do not use abrasive cleaners or sharp metal scrapers. These can scratch the glass in the oven door, which may result in the shattering of the glass.

Service

- This oven should only be repaired or serviced by an authorised Service Engineer and only genuine approved spare parts should be used.



Environmental Information

- After installation, please dispose of the packaging with due regard to safety and the environment.
- When disposing of an old appliance, make it unusable, by cutting off the cable. Remove any door catches, to prevent small children being trapped inside.



- The symbol  on the product or on its packaging indicates that this product should not be treated as normal household waste. Instead it should be taken to the appropriate collection facility for the recycling of electrical and electronic equipment. By ensuring this product is disposed of correctly, you will help prevent potential negative consequences for the environment and human health, which could otherwise be caused by inappropriate waste handling of this product. For more detailed information about recycling of this product, please contact your local council, your household waste disposal service or the shop where you purchased the product.

Contents

For the User

Important Safety Information	2
Description of the Appliance	4
The Control Panel	7
Controls	8
When the Oven is first installed	9
Electronic Programmer	10
Setting the time of day	10
“Cooking duration” function	10
“End of cooking” function	11
“Cooking duration” and “End of cooking time” combined	11
“Minute timer” function	11
How to switch off the display	11
Using the Oven	12
Oven accessories	12
Hints and Tips	13
Condensation and steam	13
Cookware	13
The effects of dishes on cooking results	13
The Safety Thermostat	13
The Cooling Fan	13
The Fan Oven	14
How to use the Fan Oven	14
Hints and Tips	14
Cooking chart - Fan Oven	15
Grilling	16
Cooking chart - Grilling	16
Defrosting	17
Cleaning the Oven	18
Cleaning materials	18
External cleaning	18
Oven Cavity	19
Oven Shelves and Shelf Supports	19
Cleaning the Hinged Grill	19
Replacing the Oven Light	20
Something not working	21
Repairs - After Sales Service	22

For the Installer

Installation	5
Technical Data	5
Heating elements rating	5
Electrical Connection	5
Building In	6
Securing The Oven To The Cabinet	6

Guide to use the Instruction Manual

The following symbols will be found in the text to guide you throughout the Instructions:



Safety Instructions



Step by step instructions for an operation



Hints and Tips



Environmental Information



This appliance complies with the following **E.E.C. Directives:**

* **2006/95**

(Low Voltage Directive);

* **93/68** (General Directives);

* **89/336** (Electromagnetic Compatibility Directive)

and subsequent modifications.

Description of the Appliance

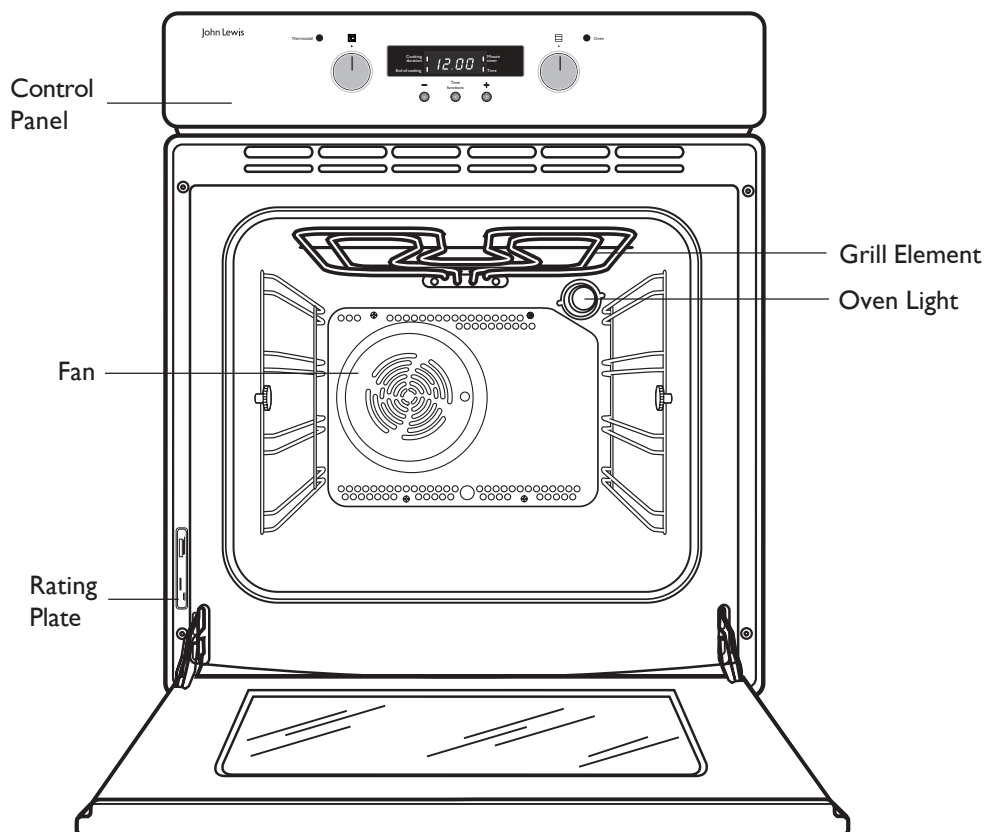

Installation

Technical Data

Dimensions of recess

Height	in-column: 580 mm undertop: 593 mm
Width	560 mm
Depth	550 mm

Dimensions of the oven cavity

Height	335 mm
Width	395 mm
Depth	400 mm
Oven capacity	53 litres

Heating elements rating

Fan Oven	2,000 W
Grill element	1,650 W
Convection Fan	25 W
Oven Light	25 W
Cooling Fan	25 W
Total Rating	2,075 W
Supply voltage (50 Hz)	230 V

Electrical Connection

 **THIS OVEN MUST BE EARTHED**

Electrical Requirements

Any permanent electrical installation must comply with the latest I.E.E. Regulations and local Electricity Board regulations. For your own safety this should be undertaken by a qualified electrician, e.g. your local Electricity Board, or a contractor who is on the roll of the National Inspection Council for Electrical Installation Contracting (NICEIC).

Electrical Connection

The oven is designed to be connected to 230 V (50 Hz) electricity supply.

Before connecting to the mains supply ensure that the mains voltage corresponds to the voltage on the rating plate on the side of the oven door.

The oven has an easily accessible terminal block which is marked as follows:

Letter L	-	Live terminal
Letter N	-	Neutral terminal
 or E	-	Earth terminal

The cable used to connect the oven to the electrical supply must comply to the specifications given below.

For UK use only

Connection via	Min. size Cable/flex	Cable / flex type	Fuse
<ul style="list-style-type: none"> 13 A socket outlet 13 A spur box 	2.5 mm ²	3 core butyl insulated	13 A min.
<ul style="list-style-type: none"> Oven Control Circuit 	2.5 mm ²	PVC/PVC twin and earth	15 A min. 20 A max.

It is necessary that you install a double pole switch between the oven and the electricity supply (mains), with a minimum gap of 3 mm between the switch contacts and of a type suitable for the required load in compliance with the current rules.

 **The switch must not break the yellow and green earth cable at any point.**

It is necessary that the yellow/green earth wire is about 2 cm longer than the live and neutral ones.

Important

After installation and connecting, the cable must be placed so that it cannot at any point reach a temperature of more than 60°C above the ambient temperature.

Before the oven is connected, check that the main fuse and the domestic installation can support the load; and that the power supply is properly earthed.

The manufacturer disclaims any responsibility should these safety measures not be carried out.

For Europe use only

Min. size Cable/flex	Cable / flex type	Fuse
1.5 mm ²	H07 RN-F, H05 RN-F, H05 RR-F, H05 VV-F, H05 V2V2-F (T90), H05 BB-F	13 A

Building In



The oven must be installed according to the instructions supplied on p. 5-6 and by qualified and competent personnel to the relevant National Standards

Please ensure that when the oven is installed it is easily accessible for the engineer in the event of a breakdown.

Building In

The surround or cabinet into which the oven will be built must comply with these specifications:

- the dimensions must be as shown in the relevant diagrams;
- the materials must withstand a temperature increase of at least 60°C above ambient;
- proper arrangements must be made of a continuous supply of air to the oven to prevent the oven overheating.

Dimensions of the oven and recess required are given in the relevant diagrams.

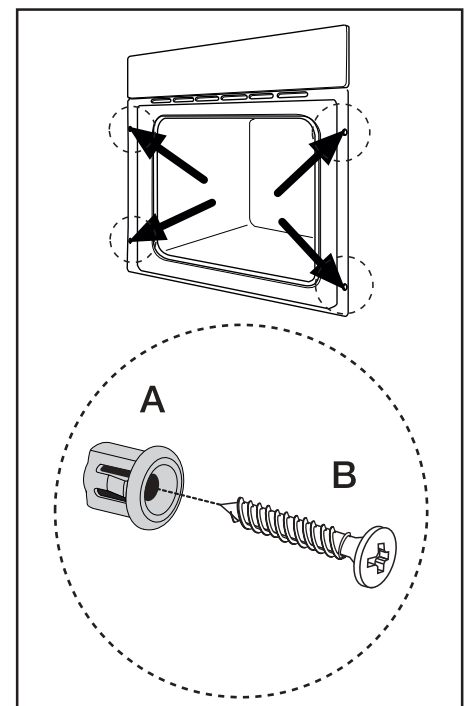
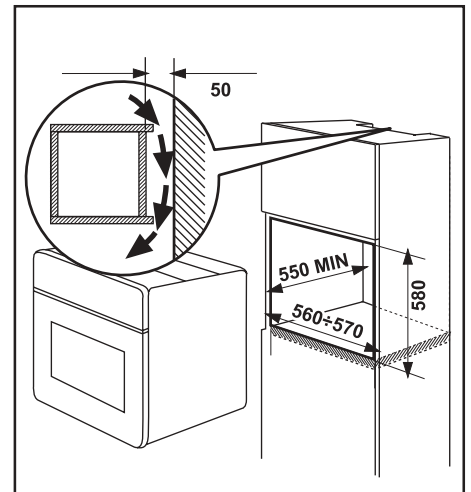
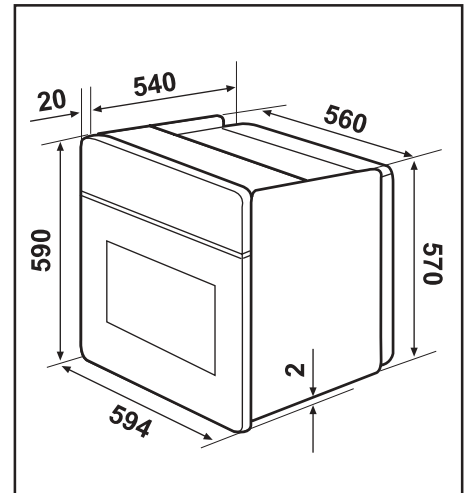
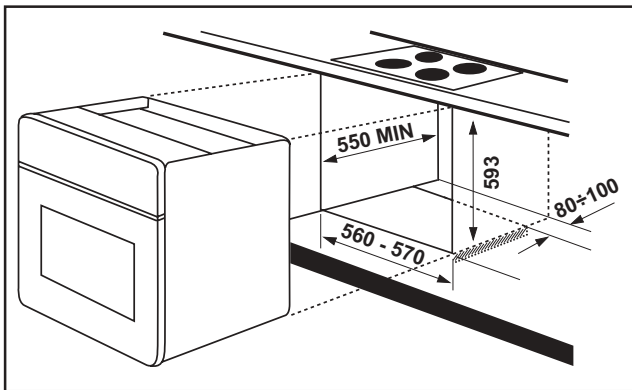

Securing The Oven To The Cabinet

1. Fit the oven into the cabinet recess,
2. Open the oven door,
3. Secure the oven to the kitchen cabinet with the four distance holders "A" which fit the holes in the oven frame and then fit the four wood screws "B".

The Control Panel

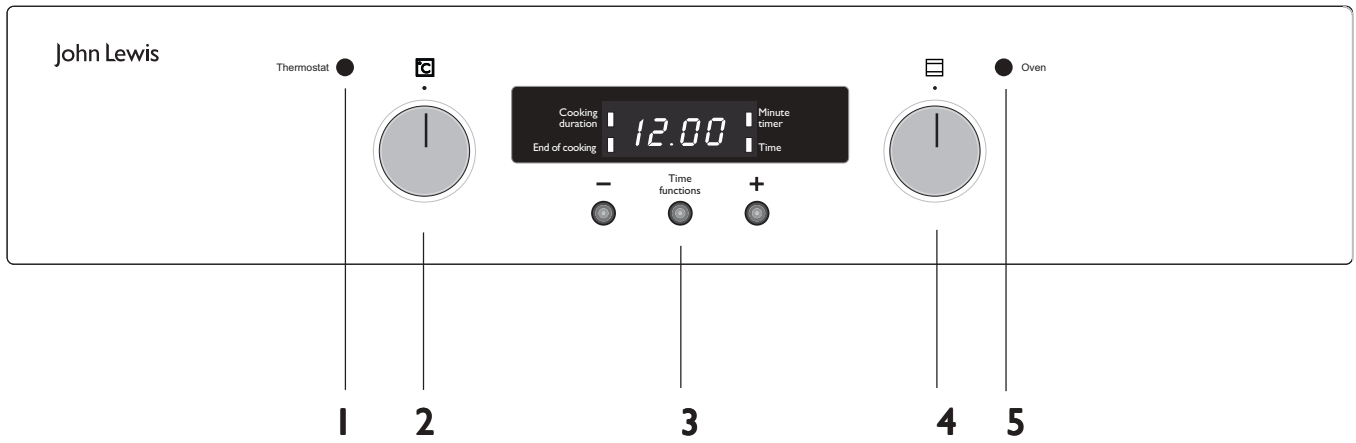

1. Thermostat Control Light
2. Thermostat Control Knob
3. Electronic Programmer
4. Oven Function Control Knob
5. Mains on Light



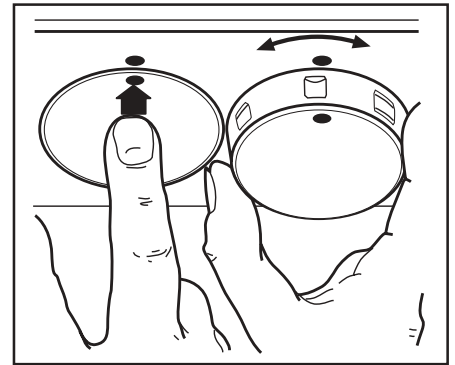

Controls

Push-Pull control knobs

The oven is provided with push-pull control knobs. These knobs can be completely sunken inside the control panel when the oven is not working.



Oven Function Control Knob

-  **Oven Light** - The oven light will be on without any cooking function.
-  **Defrost Setting** - This setting is intended to assist in thawing of frozen food.
-  **Fan cooking** - This allows you to roast or roast and bake simultaneously using any shelf, without flavour transference.
-  **Grill** - The heat comes from the top element only.

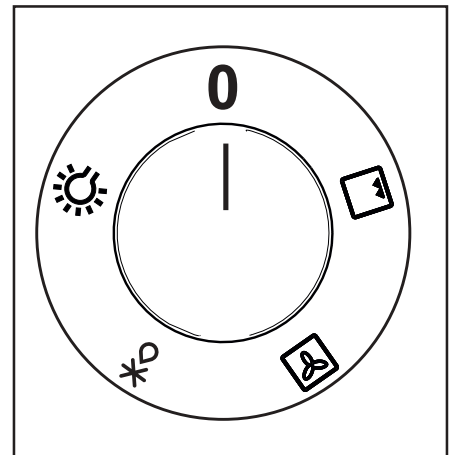

Thermostat Control Knob

Turn the thermostat control knob clockwise to select temperatures between 50°C and MAX (250°C).

Thermostat Control Light

The thermostat control light will come on when the thermostat control knob is turned. The light will remain on until the correct temperature is reached. It will then cycle on and off to show the temperature is being maintained.

Mains on Light

The mains on light will come on when the oven function control knob is set.

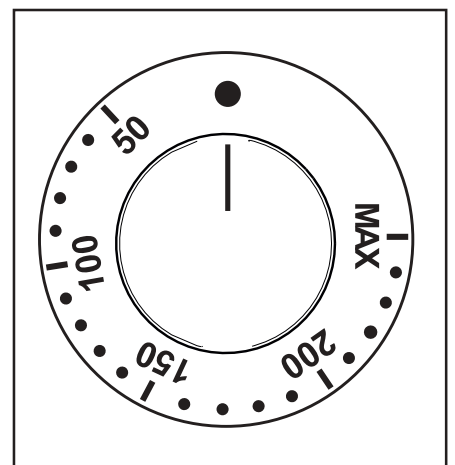

When the Oven is first installed



Remove all packaging, both inside and outside the oven including the advertising labels and any protective film, before using the oven.

Before first use, the oven should be heated without food.



The oven will work only if the time of day has been set.



1. Set the time of day with the electronic programmer (see chapter "Electronic Programmer").
2. Switch the oven function control knob to fan cooking



3. Set the thermostat control knob to MAX.
4. Open a window for ventilation.
5. Allow the oven to run empty for approximately 45 minutes.

This procedure should be repeated with the grill  function for approximately 5-10 minutes.



During this time, an unpleasant odour may be emitted. This is absolutely normal, and is caused by residues of manufacturing.

Once this operation is carried out, let the oven cool down, then clean the oven cavity with a soft cloth soaked in warm water to which a little mild washing-up liquid has been added.



Before cooking for the first time, carefully wash the shelves and the baking tray.



To open the oven door, always hold the handle in the centre.

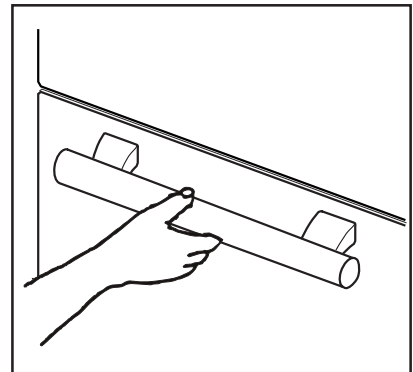

Electronic Programmer

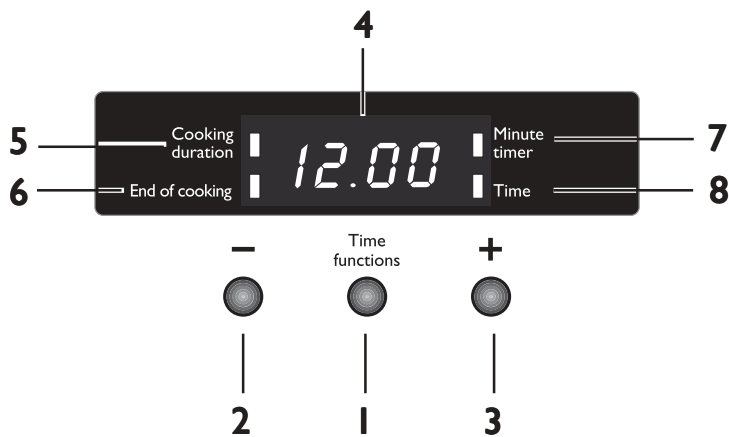

1. "Time functions" control button
2. Decreasing control button "–"
3. Increasing control button "+"
4. Display
5. "Cooking duration" pilot lamp
6. "End of cooking" pilot lamp
7. "Minute timer" pilot lamp
8. "Time" pilot lamp

- i** The oven will work only if the time of day has been set. However, the oven can also be operated without any programme.
- i** In the event of a power failure, all the settings (time of day, programme setting or programme in operation) will be cancelled. When the power is restored, the numbers in the display will flash, and the clock/timer has to be reset.

Setting the correct time of day

When the power supply is switched on, or after a power failure, the "Time" pilot lamp will flash on the display.

To set the correct time of day:

1. Press button "+" or "–" (Fig. 1).
2. After the setting is carried out, wait for 5 seconds: the "Time" pilot lamp will go out and the display will show the set time. The appliance is ready for use.

To reset the correct time of day:

1. Press "Time functions" button repeatedly to select the time of day function. The relevant pilot lamp will start flashing. Then proceed as described above. The time of day can only be reset if no automatic function (Cooking duration or End of cooking) has been set.

"Cooking duration" function

This function allows the oven to automatically switch off at the end of a programmed cooking duration time. Place food in the oven, select a cooking function and adjust the cooking temperature. Press "Time functions" button repeatedly to select the "Cooking duration" function. The relevant pilot lamp will start flashing (Fig. 2). Then, proceed as follows:

To set the duration time:

1. Press button "+" or "–" (Fig. 3).
2. After the setting is carried out, wait for 5 seconds: the "Cooking duration" pilot lamp will come on and the display will revert to the time of day.
3. When cooking time is over, the oven will be switched off automatically and an acoustic alarm will be heard, while the pilot lamp will start flashing. Turn the oven function and the thermostat control knob to zero. To switch off the acoustic alarm, press any button.

NOTE: Turning the acoustic alarm off will reset the oven to manual, and if the oven function and the thermostat knobs are not set to zero the oven will start to heat again.

To cancel the duration time:

1. Press "Time functions" button repeatedly to select the "Cooking duration" function. The relevant pilot lamp will flash and the display will show the remaining cooking time.
2. Press button "–" until the display shows "0:00". After 5 seconds the pilot lamp will go out and the display will revert to the time of day.

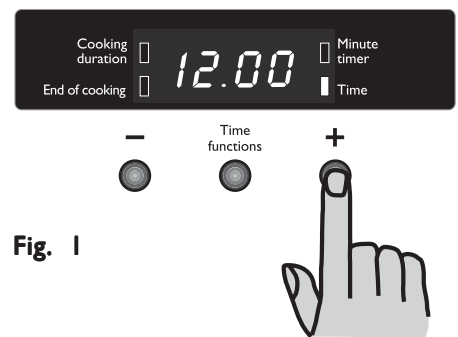

Fig. 1

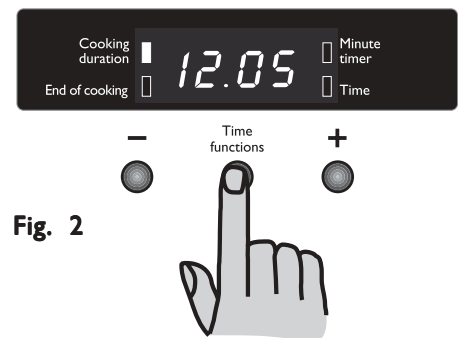

Fig. 2

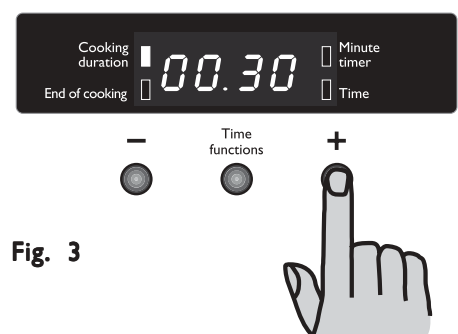

Fig. 3

“End of cooking” function

With this function, you can set the oven to switch off automatically when a programmed end of cooking time is over. Place food in the oven, select a cooking function and adjust the cooking temperature. Press “Time functions” button repeatedly to select the “End of cooking” function. The relevant pilot lamp will start flashing (Fig. 4). Then, proceed as follows:

To set the End of cooking time:

1. Press button “+” or “-” (Fig. 5).
2. After the setting is carried out, wait for 5 seconds: the “End of cooking” pilot lamp will come on and the display will revert to the time of day.
3. When cooking time is over, the oven will be switched off automatically and an acoustic alarm will be heard, while the pilot lamp will start flashing. Turn the oven function and the thermostat control knob to zero.

To switch off the acoustic alarm, press any button.

NOTE: Turning the acoustic alarm off will reset the oven to manual, and if the oven function and the thermostat knobs are not set to zero the oven will start to heat again.

To cancel the End of cooking time:

1. Press “Time functions” button repeatedly to select the “End of cooking” function. The relevant pilot lamp will flash and the display will show the programmed end of cooking time.
2. Press button “-” until the display shows the current time of day. The programmer will beep and the pilot lamp will go out.

“Cooking duration” and “End of cooking time” combined

The functions “Cooking duration” and “End of cooking time” can be used simultaneously to set the oven to switch on and off automatically at a later time (Fig. 6).

1. With the “Cooking duration” function (carry out the cooking duration setting as described in the relevant chapter) set the duration time. Then, press “Time functions” button: the display will show the programmed setting.
2. With the “End of cooking time” function (carry out the end of cooking setting as described in the relevant chapter) set the end of cooking time. The relevant pilot lamps will come on and the display will show the time of day. The oven will switch on and off according to the set programmes.

“Minute timer” function

The minute timer alarm will sound at the end of a timed period, but THE OVEN WILL REMAIN ON, if it is in use.

To set the minute timer :

1. Press “Time functions” button repeatedly to select the “Minute timer” function. The relevant pilot lamp will start flashing.
2. Then, press button “+” or “-” (maximum: 2 hours, 30 minutes - Fig. 7).
3. After the setting is carried out, wait for 5 seconds: the “Minute timer” pilot lamp will come on.
4. At the end of the timed period, the pilot lamp will start flashing and an acoustic alarm will be heard. To switch off the acoustic alarm, press any button.

To cancel the minute timer:

1. Press “Time functions” button repeatedly to select the “Minute timer” function. The relevant pilot lamp Σ will flash and the display will show the remaining time.
2. Press button “-” until the display shows “0:00”. After 5 seconds the pilot lamp will go out and the display will revert to the time of day.

How to switch off the display

1. Press two or three programmer push buttons simultaneously and keep them pressed for about 5 seconds (Fig. 8). The display will switch off.
2. To switch on the display, press any button.

The display can be switched off only if no other functions have been set.



Fig. 4

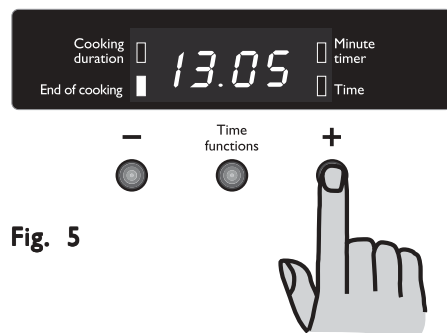

Fig. 5

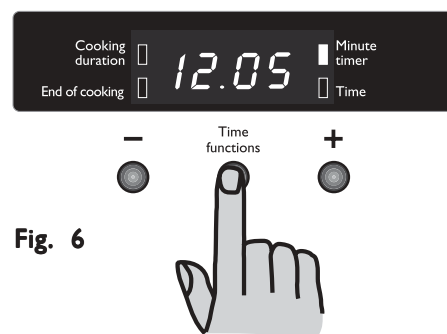

Fig. 6

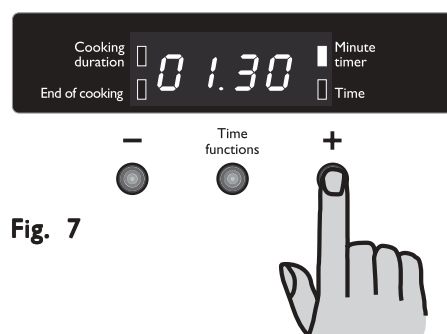

Fig. 7

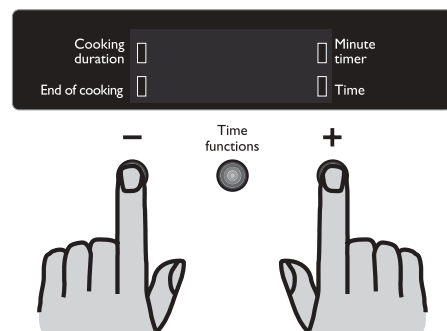

Fig. 8

Using the Oven

Always cook with the oven door closed. Stand clear when opening the oven door.

The oven has four shelf levels. The shelf positions are counted from the bottom of the oven as shown in the diagram.

It is important that these shelves are correctly positioned as shown in the diagram.



Do not place cookware directly on the oven base.

Warning: Do not cover any part of the oven with aluminium foil while cooking, as this could cause a heat build-up which would affect the baking results and damage the oven enamel. Always place pans, heat-resisting pans and aluminium trays on the shelf which has been inserted in the shelf runners.

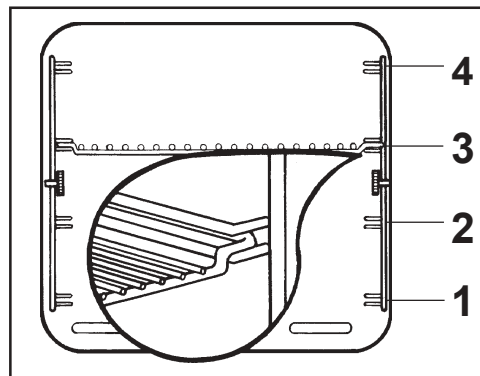

Oven accessories

Grill/roasting pan

Grill trivet

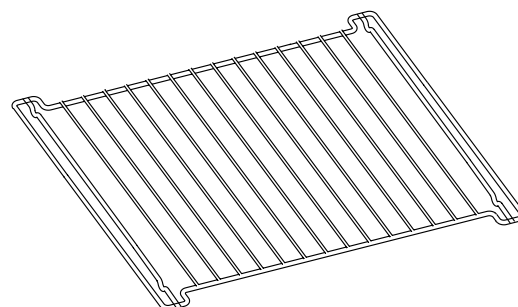
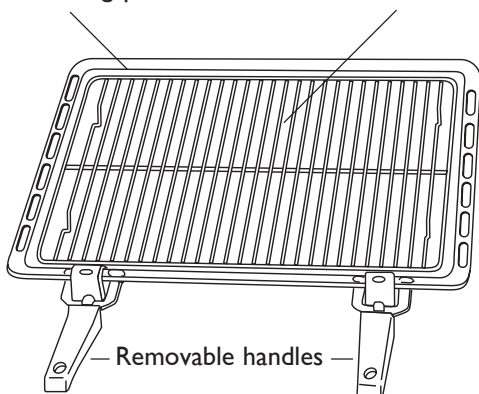

Shelf (x 2)

i Hints and Tips

Condensation and steam

Condensation and Steam

The oven is supplied with an exclusive system which produces a natural circulation of air and the constant recycling of steam. This system makes it possible to cook in a steamy environment and keep the dishes soft inside and crusty outside. Moreover, the cooking time and energy consumption are reduced to a minimum. During cooking steam may be produced which can be released when opening the oven door. This is absolutely normal.

! **Always stand back from the oven when opening the oven door during cooking or at the end of it to allow any build up of steam or heat to release.**

i When food is heated, it produces steam in the same way as a boiling kettle does. When steam comes in contact of the oven door glass, it will condense and produce water droplets.

To reduce condensation, ensure the oven is well heated before placing food in the oven cavity. A short oven pre-heating (about 10 minutes) will then be necessary before any cooking.

We recommend you to wipe away condensation after each use of the appliance.

Cookware

- Use any oven proof cookware which will withstand temperatures of 250°C.
- Baking trays, oven dishes, etc. should not be placed directly against the grid covering the fan at the back of the oven, or placed on the oven base.
- Do not use baking trays larger than 30 cm x 35 cm (12 in x 14 in) as they will restrict the circulation of heat and may affect performance.

The effects of dishes on cooking results

Dishes and tins vary in their thickness, conductivity, colour, etc. which affects the way they transmit heat to the food inside them.

- A** Aluminium, earthenware, oven glassware and bright shiny utensils reduce cooking and base browning.
- B** Enamelled cast iron, anodised aluminium, aluminium with non-stick interior and coloured exterior and dark, heavy utensils increase cooking and base browning.

The Safety Thermostat

This oven is provided with a safety thermostat. In case of malfunctioning of the main thermostat, and consequent overheating, the safety device will stop the power supply to the appliance. If this happens, call your local repair agent. Under no circumstances should you attempt to repair the appliance yourself.

The Cooling Fan

The oven is provided with a cooling fan, meant to keep the front panel, the knobs and the oven door handle cool. The cooling fan operates during cooking. Air is expelled through vents between the oven door and the control panel, as shown in the diagram.

The cooling fan may run on after the oven is switched off to keep the controls cool. This is quite normal.

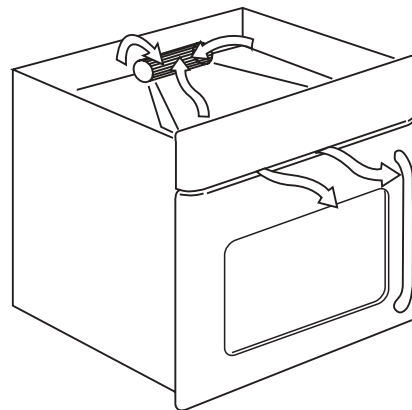

The Fan Oven

The air inside the oven is heated by the element around the fan situated behind the back panel. The fan circulates hot air to maintain an even temperature inside the oven.

The advantage of cooking with this function is energy saving through:

- **Faster Preheating**

As the fan oven quickly reaches temperature, it is not usually necessary to preheat the oven although you may find that you need to allow an extra 5-7 minutes on cooking times. For recipes which require higher temperatures, best results are achieved if the oven is preheated first, e.g. bread, pastries, scones, souffles, etc.

- **Lower Temperatures**

Fan oven cooking generally requires lower temperatures than conventional cooking.

Follow the temperatures recommended in the cooking chart. Remember to reduce temperatures by about 20-25°C for your own recipes which use conventional cooking.

- **Even Heating for Baking**

The fan oven has uniform heating on all shelf positions. This means that batches of the same food can be cooked in the oven at the same time. However, the top shelf may brown slightly quicker than the lower one. This is quite usual. There is no mixing of flavours between dishes.

How to use the Fan Oven

1. Turn the oven function control knob to .
2. Turn the thermostat control to the required temperature.

THINGS TO NOTE

- The oven light will come on when the oven function control knob is set.
- The oven fan will operate continually during cooking.
- The thermostat control light will remain on until the correct temperature is reached. It will then cycle on and off to show the temperature is being maintained.

The cooling fan

During cooking the cooling fan will operate continually. It may run on after the oven is switched off to keep the controls cool. This is quite normal.

NOTE

The action of the cooling fan will depend on how long the oven has been used and at what temperature. It may not switch in at all at lower temperature settings nor run on where the oven has only been used for a short time.

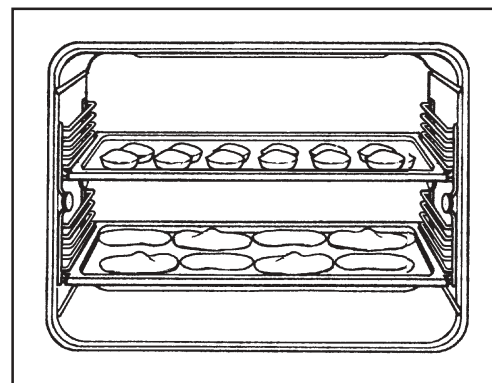

Hints and Tips

Shelf positions are not critical, but make sure the shelves are evenly spaced.

When cooking more than one dish in the fan oven, place dishes centrally on the shelves rather than several dishes on one shelf.

When the oven is full, you may need to allow slightly longer cooking time.

When the oven is full of the same food, e.g. equal trays of small cakes or equal size victoria sandwich cakes, then they will be cooked in the same time and removed from the oven together. When different sizes of trays or types of food, e.g. biscuits and cakes are cooked, they will not necessarily be ready together.

The fan oven can be used to heat foods through without thawing first, e.g. fruit tarts, mince pies, sausage rolls, and other small pastry items. Use a temperature of 190-200°C and allow 20-40 minutes (depending on the quantity of food in the oven).



The use of too high temperatures can cause uneven browning. Check with the recommendations for oven temperatures given in the cooking charts, but be prepared to adjust the temperature, if necessary. Remember to reduce temperatures by about 20-25°C for your own conventional recipes.

When roasting do use the trivet in the meat tin. Fat and meat juices will drain into the meat tin below and can be used to make gravy. The trivet also prevents splashes of fat from soiling the oven interior.

The meat tin **should not** be placed on a heated hotplate as this may cause the enamel to crack.

Cooking Chart- Fan Oven

i This chart is intended as a guide only. It may be necessary to increase or decrease the temperature to suit your individual requirements. Only experience will enable you to determine the correct setting for your personal requirements. **Cooking times do not include pre-heating time. A short oven pre-heating (about 10 minutes) is necessary before any cooking.**

Weight (gr.)	TYPE OF DISH	Level 	Cooking temperature (°C)	Cooking time  minutes	NOTES
	CAKES				
	Whisked recipies	2 (1 and 3)*	160	45-60	In cake mould
	Shortbread dough	2 (1 and 3)*	160	20-30	In cake mould
	Butter-milk cheese cake	2	165	60-80	In cake mould
	Apple cake	2	160	90-120	In cake mould
	Strudel	2	160	60-80	In baking tray
	Jam- tart	2	180	40-45	In cake mould
	Fruit cake	2	150	60-70	In cake mould
	Sponge cake	2 (1 and 3)*	165	30-40	In cake mould
	Christmas cake	2	150	120-150	In cake mould
	Plum cake	2	160	50-60	In bread tin
	Small cake	2	160	20-35	In baking tray
	Small cake	2 (1 and 3)*	170	25-35	In baking tray
	Biscuits	2 (1 and 3)*	150	20-30	In baking tray
	Meringues	2 (1 and 3)*	150	60-90	In baking tray
	Buns	2 (1 and 3)*	180	12~20	In baking tray
	Pastry: Choux	2 (1 and 3)*	170	25-35	In braking tray
	BREAD AND PIZZA				
1000	White bread	2	185	60-70	1-2 pieces in baking tray
500	Rye bread	1	180	30-45	In bread tin
500	Bread rolls	2 (1 and 3)*	175	25-40	6-8 rolls in baking tray
250	Pizza	2 (1 and 3)*	200	25-35	on baking tray
	FLANS				
	Pasta flan	2 (1 and 3)*	175	40-50	in mould
	Vegetable flan	2 (1 and 3)*	175	45-60	in mould
	Quiches	2 (1 and 3)*	180	35-45	in mould
	Lasagne	2	200	25-35	in mould
	Cannelloni	2	200	40-55	in mould
	Yorkshire pudding	2	210	20-25	6 puddings in mould
	MEAT				
1000	Beef	2	175	50-70	On grid
1200	Pork	2	175	100-130	On grid
1000	Veal	2	175	90 ~ 120	On grid
1500	English roast beef				
1500	rare	2	200	50 ~ 60	On grid
1500	medium	2	200	60 ~ 70	On grid
1500	well done	2	200	70 ~ 80	On grid
2000	Shoulder of pork	2	170	120 ~ 150	With rind
1200	Shin of pork	2	160	100 ~ 120	2 pieces
1200	Lamb	2	175	110 ~ 130	Leg
1000	Chicken	2	200	70-85	Whole
4000	Turkey	2	160	210 ~ 240	Whole
1500	Duck	2	220	120 ~ 150	Whole
3000	Goose	1	160	150 ~ 200	Whole
1200	Rabbit	2	175	60 ~ 80	Cut in pieces
1500	Hare	2	175	150 ~ 200	Cut in pieces
800	Pheasant	2	175	90 ~ 120	Whole
	Meat loaf	2	170	40 ~ 60	in bread pan
	FISH				
1200	Trout/Sea bream	2 (1 and 3)*	175	40-55	3-4 fishes
1500	Tuna fish/Salmon	2 (1 and 3)*	175	35-60	4-6 fillets

(*) If you need to cook more than one dish at the same time, we recommend you to place them on the levels quoted between brackets. Shelf positions are counted from bottom of the oven.

If you wish to cook more than one dish at the same time, we suggest that you change the cooking levels of your dishes during the last 5-10 minutes in order to obtain a more uniform colour of your dishes.

Grilling



Grilling must be carried out with the oven door closed.

The grill pan handles must be removed from the pan during grilling. Always use oven gloves to remove and replace the grill pan handles. Ensure that you support the grill pan when removing it from the oven.

How to Use the Grill

1. Turn the oven control function knob on .
2. Turn the thermostat control knob on the required temperature.
3. Adjust the grid and grill pan runner position to allow for different thicknesses of food. Position the food close to the element for faster cooking and further away for more gentle cooking.

Preheat the grill on a full setting for a few minutes before sealing steaks or toasting. Adjust the heat setting and the shelf as necessary, during cooking.

During cooking, the cooling fan and the thermostat control light will operate in the same way as described for the fan oven function.

Hints and Tips

Most foods should be placed on the grid in the grill pan to allow maximum circulation of air to lift the food out of the fats and juices. Food such as fish, liver and kidneys may be placed directly on the grill pan, if preferred.

Food should be thoroughly dried before grilling to minimise splashing. Brush lean meats and fish lightly with a little oil or melted butter to keep them moist during cooking.

Accompaniments such as tomatoes and mushrooms may be placed underneath the grid when grilling meats.

When toasting bread, we suggest that the top runner position is used.

The food should be turned over during cooking, as required.

The grill element is controlled by the thermostat. During cooking, the grill cycles on and off to prevent overheating.

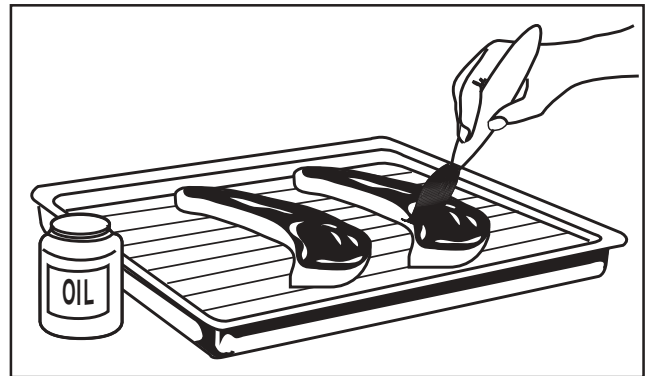



Cooking Chart - Grilling

A general guide to cooking times is given below but these times may vary slightly depending on the thickness and quantity of food being cooked.



Cooking times do not include pre-heating time. A short oven pre-heating (about 10 minutes) is necessary before any cooking.

TYPE OF DISH	Quantity		Grilling		Cooking time (minutes) 	
	Pieces	Weight	Level 	temp. °C	Upper side	Lower side
Fillet steaks	4	800	3	max	12 ~ 15	12 ~ 14
Beef-steaks	4	600	3	max	10 ~ 12	6 ~ 8
Sausages	8	—	3	max	12 ~ 15	10 ~ 12
Pork chops	4	600	3	max	12 ~ 16	12 ~ 14
Chicken (cut in two)	2	1000	3	max	30 ~ 35	25 ~ 30
Kebabs	4	—	3	max	10 ~ 15	10 ~ 12
Chicken (breast)	4	400	3	max	12 ~ 15	12 ~ 14
Hamburger	6	600	2	max	10 ~ 15	8 ~ 10
Fish (fillets)	4	400	3	max	12 ~ 14	10 ~ 12
Sandwiches	4-6	—	3	max	5 ~ 7	—
Toast	4-6	—	3	max	2 ~ 4	2 ~ 3

Defrosting

The oven fan operates without heat and circulates the air, at room temperature, inside the oven. This increases the speed of defrosting. However, please note that the temperature of the kitchen will influence the speed of defrosting.

This function is particularly suitable for delicate food which could be damaged by heat, e.g. cream filled gateaux, iced cakes, pastries, bread and other yeast products.

How to Use Defrosting

1. Turn the oven function control knob to .
2. Ensure the thermostat control knob is in the OFF position.

Hints and Tips

- Cover food with a lid, aluminium foil or plastic film to prevent drying out during defrosting.
- ALWAYS COOK THOROUGHLY IMMEDIATELY AFTER THAWING.
- Frozen food should be placed in a single layer when ever possible and turned over half way through the defrosting process.
- Only joints of meat and poultry up to 2 kg. (4 lb.) are suitable for defrosting in this way.

Cleaning the Oven



Before cleaning always allow the cooling fan to cool the oven down before switching off at the electricity supply.

This appliance cannot be cleaned with steam or with a steam cleaning machine.

The oven should be kept clean at all times. A build-up of fats or other foodstuffs could result in a fire, especially in the grill pan.

Cleaning materials

Before using any cleaning materials on your oven, check that they are suitable and that their use is recommended by the manufacturer.

Cleaners that contain bleach should NOT be used as they may dull the surface finishes. Harsh abrasives should also be avoided.

External cleaning

Regularly wipe over the control panel, oven door and door seal using a soft cloth well wrung out in warm water to which a little mild washing-up liquid has been added.



To prevent damaging or weakening the door glass panels avoid the use of the following:

- Household detergent and bleaches
- Impregnated pads unsuitable for non-stick saucepans
- Brillo/Ajax pads or steel wool pads
- Chemical oven pads or aerosols
- Rust removers
- Bath/Sink stain removers

Before cleaning the oven door, we recommend you to remove it from the oven.

Proceed as follows:

1. open the oven door completely;
2. find the hinges linking the door to the oven (see diagram 1);
3. unlock and turn the small levers located on the two hinges (see diagram 2);
4. handle the door by its left- and right-hand sides, then slowly turn it towards the oven until it is half-closed (see diagram 3);
5. gently pull the oven door off its site (see diagram 3);
6. place it on a steady plan;

Clean the outer and inner door glass using warm soapy water. Should the inner door glass become heavily soiled it is recommended that a cleaning product such as Hob Brite is used. Do not use paint scrapers to remove soilage.



DO NOT clean the oven door while the glass panels are warm. If this precaution is not observed the glass panel may shatter.

If the door glass panel becomes chipped or has deep scratches, the glass will be weakened and must be replaced to prevent the possibility of the panel shattering. Contact your local Repair agent who will be pleased to advise further.

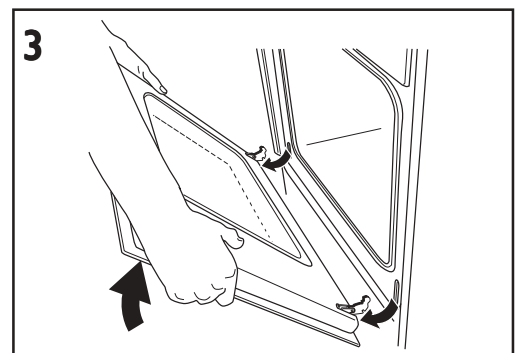
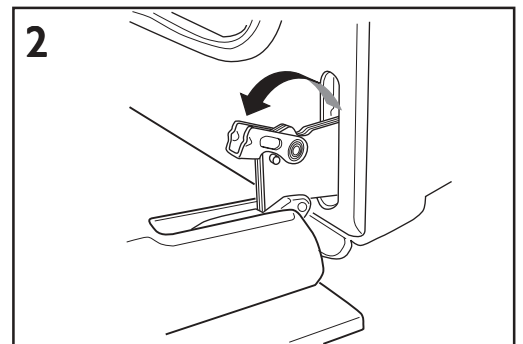
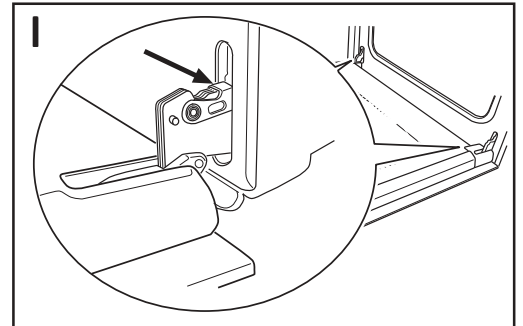

Oven Cavity

The enamelled base of the oven cavity is best cleaned whilst the oven is still warm.

Wipe the oven over with a soft cloth soaked in warm soapy water after each use. From time to time it will be necessary to do a more thorough cleaning, using a proprietary oven cleaner.

Oven Shelves and Shelf Supports

To clean the oven shelves, soak in warm soapy water and remove stubborn marks with a well wetted soap impregnated pad. Rinse well and dry with a soft cloth.

The shelf supports can be removed for easy cleaning.

☞ Proceed as follows:

- 1) remove the front screw while keeping the shelf support in position with the other hand (see diagram 4);
- 2) disengage the rear hook and take off the shelf support (see diagram 5);
- 3) once the cleaning is carried out, refit the shelf supports following the procedure in reverse.

Please, ensure the retaining nuts are secure when refitting the shelf support.

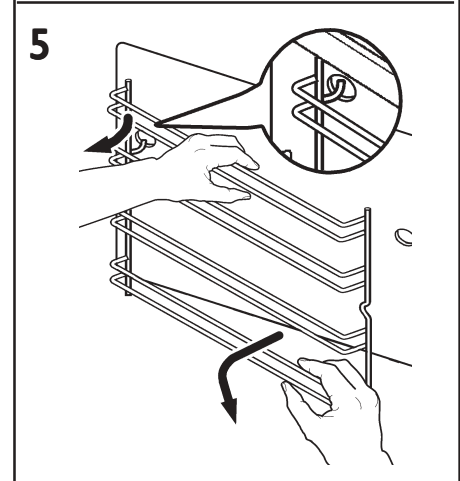
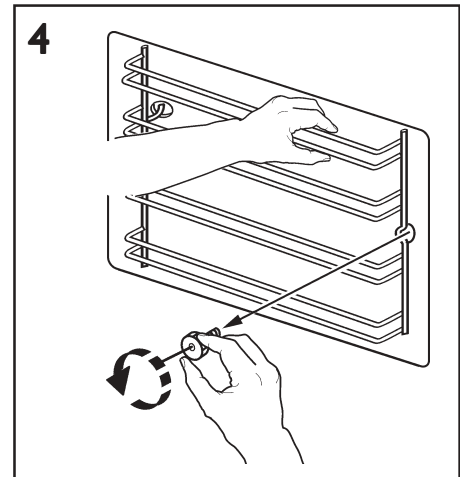

Cleaning the Hinged Grill

This model has been fitted with a hinged grill element to enable you to clean the roof of the oven easily.

⚠ Before proceeding ensure the oven is cool and is disconnected from the electricity supply.

- 1) Undo the screw which holds the grill in place (see diagram 6). When carrying out this operation for the first time, we recommend using a screwdriver.
- 2) Then, gently pull the grill downwards to allow access to the oven roof (see diagram 7).
- 3) Clean the oven roof with a suitable cleaner and wipe dry before replacing the hinged grill element.
- 4) Gently push up the grill element into place and firmly screw into place the holding nut.

⚠ Ensure the grill holding nut is firmly in place to avoid the grill falling down when in use.

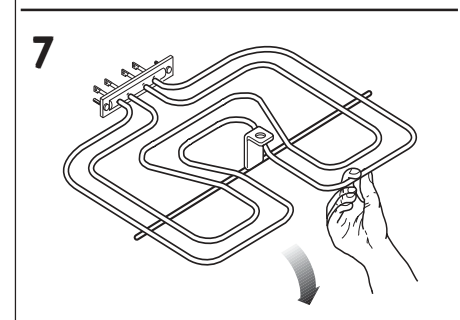
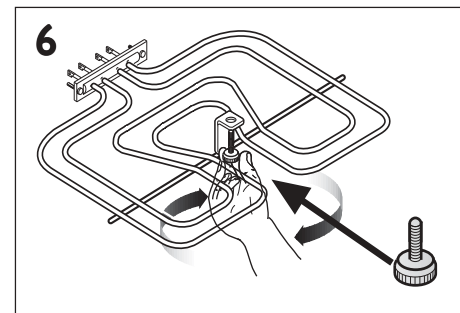

Replacing the Oven Light

If the oven bulb needs replacing, it must comply with the following specifications:

- Electric power: 15 W/25 W,
- Electric rate: 230 V (50 Hz),
- Resistant to temperatures of 300°C,
- Connection type: E14.

These bulbs are available from your local Repair agent.

 To replace the faulty bulb:

1. **Ensure the oven is disconnected from the electrical supply.**
2. Turn the glass cover anticlockwise.
3. Remove the faulty bulb and replace with the new one.
4. Refit the glass cover.
5. Reconnect to the electrical supply.

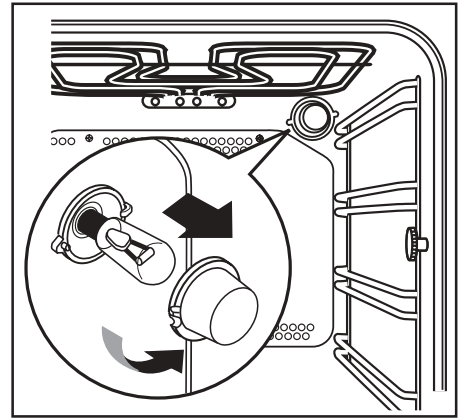

Something not working

If the oven is not working correctly, please carry out the following checks, before contacting your local repair agent.

IMPORTANT: If you call out an engineer to a fault listed below, or to repair a fault caused by incorrect use or installation, a charge will be made even if the appliance is under guarantee.

SYMPTOM	SOLUTION
■ The oven does not come on.	<ul style="list-style-type: none">◆ Check that both a cooking function and temperature have been selected.◆ Check the fuse and ensure the socket switch or the switch from the mains supply to the oven are ON.
■ The oven light does not come on.	<ul style="list-style-type: none">◆ Select a function with the oven function control knob.◆ Check the light bulb, and replace it if necessary (see "Replacing the Oven Light").
■ It takes too long to finish the dishes, or they are cooked too fast.	<ul style="list-style-type: none">◆ The temperature may need adjusting◆ Refer to the cooking function sections and to any cooking chart provided.
■ Steam and condensation settle on the food and the oven cavity.	◆ Leave dishes inside the oven no longer than 15-20 minutes after the cooking is completed.
■ The electronic timer does not work.	◆ Check the instructions for the timer.
■ The oven fan is noisy.	◆ Check that shelves and bakeware are not vibrating in contact with the oven back panel.
■ The display shows "12.00".	◆ Set the time of day (see chapter "Setting the time of day").

Repairs - After Sales Service

If your oven is not performing satisfactorily; consult the fault finding guide within this instruction book (Something not working). In the event of a fault occurring which you cannot resolve yourself from advice given within this instruction manual your first step is to contact our extended warranty administrators on **0870 0107887** who will give you details for your local repair agent.

When contacting the repair agent, please quote the model (Mod.) and serial number (S.N.), both of which are shown on the rating plate located on the side of the oven door (see picture).

So that you always have these numbers at hand, we recommend you to make a note of them here:

Mod. :

PNC :

S.N. :

Your oven is covered by a 3 year parts and labour guarantee (see separate details given at point of sale). Please retain your purchase receipt safely for the service engineer to verify the purchase details.

Spare parts

This product should be serviced by an authorised service engineer, and only genuine spare parts should be used.

Under no circumstances should you attempt to repair the oven yourself.

Repairs carried out by inexperienced persons may cause injury or serious malfunctioning. Contact our extended warranty administrators on **0870 0107887** who will give you details for your local repair agent.

Always insist on genuine spare parts.

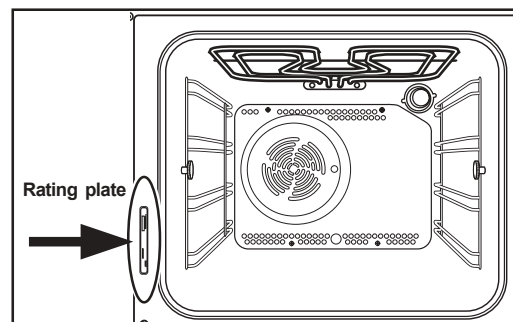

-	ES	DA	DE	EL	EN	FR	IT	NL	PT	SV	FI	
1	Fabricante	Mærke	Hersteller	Προμηθευτής	Manufacturer	Fabricant	Costruttore	Fabrikant	Fabricante	Leverantör	Tavarantontittaja	John Lewis
2	Modelo	Model	Modell	Μοντέλο	Model	Modèle	Modello	Model	Modelo	Modell	Malli	JLBIOS601
3	Clase de eficiencia energética	Relativt energiforbrug	Energieeffizienzklasse	Τάξη ενεργειακής απόδοσης	Energy efficiency class	Classement selon son efficacité énergétique	Classe di efficienza energetica	Energie-efficiëntieklasse	Classe de eficiência energética	Energieeffektivitetsklass	Energiatehokkuusluokka	
4	- Calentamiento convencional	- Traditionel opvarmning	- Konventionelle Beheizung	- Συμβατική	- Conventional	- Classique	- Convezione naturale	- Conventioneel	- Conveccional	- Konventionell värmning	- Ylä-alalämpö	
5	- Convección forzada	- Varmluft	- Um/Heißluft	- Με κυκλοφορία θερμού αέρα	- Forced air convection	- Convection forcée	- Convezione forzata	- Geforceerde luchtconvector	- Convecção forçada de ar	- Värmning med varmluft	- Kiertoilma	
	Consumo de energía Función de calentamiento:	Energiforbrug Opvarmningsfunktion:	Energieverbrauch Beheizung:	Κατανάλωση ενέργειας Λειτουργία θέρμανσης	Energy consumption Heating function:	Consommation d'énergie Fonction chauffage:	Consumo di energia Funzione di riscaldamento:	Energieverbruik Verhittingsfunctie:	Consumo de energia Função de aquecimento:	Energiförbrukning Värmningsfunktion:	Energiankulutus Kuumennustapa:	
6	- Calentamiento convencional	- Traditionel opvarmning	- Konventionelle Beheizung	- Συμβατική	- Conventional	- Classique	- Convezione naturale	- Conventioneel	- Conveccional	- Konventionell värmning	- Ylä-alalämpö	
7	- Convección forzada	- Varmluft	- Um/Heißluft	- Με κυκλοφορία θερμού αέρα	- Forced air convection	- Convection forcée	- Convezione forzata	- Geforceerde luchtconvector	- Convecção forçada de ar	- Värmning med varmluft	- Kiertoilma	0,78 kWh
8	- Vapor	- Dampf	- Dampf	- Ατμός	- Steam	- Vapeur	- Vapore	- Stoom	- Vapor	- Ånga	- Höyry	
9	Volumen neto (litros)	Nettovolumen (liter)	Nettovolumen (Liter)	Ωφέλιμος όγκος (λίτρα)	Usable volume (litres)	Volume utile (litres)	Volume utile (litri)	Netto volume (liter)	Volume útil Litros	Användbar volym (liter)	Käyttötilavuus (litraa)	53,0
	●●●●● Pequeño - Medio - Grande	Type: - Lille - Mellemstort - Stort	Type: - Klein - Mittel - Groß	Τύπος: - Μικρός - Μεσαίος - Μεγάλος	Size: - Small - Medium - Large	Type: - Faible volume - Volume moyen - Grand volume	Type: - Piccolo - Medio - Grande	Type: - Klein - Middelgroot - Groot	Type: - pequeno - médio - grande	Storlek: - Liten - Medelstor - Stor	Koko: - Pieni - Keskikokoinen - Suuri	
	Tiempo de cocción con carga normal:	Tilberedningstid ved standardbelastning:	Kochzeit bei Standardbelastung:	Χρόνος για ψήσιμο τυποποιημένου φορτίου:	Time to cook standard load:	Temps de cuisson en charge normale:	Tempo necessario per cottura carico normale:	Bereidings-tijd bij standaardbelasting:	Tempo de cozedura da carga-padrão:	Tillagningstid för en standardlast:	Paistoaika vakiokuormalla:	
10	- Calentamiento convencional	- Traditionel opvarmning	- Konventionelle Beheizung	- Συμβατική	- Conventional	- Classique	- Convezione naturale	- Conventioneel	- Conveccional	- Konventionell värmning	- Ylä-alalämpö	43 min.
11	- Convección forzada	- Varmluft	- Um/Heißluft	- Με κυκλοφορία θερμού αέρα	- Forced air convection	- Convection forcée	- Convezione forzata	- Geforceerde luchtconvector	- Convecção forçada de ar	- Värmning med varmluft	- Kiertoilma	41 min.
12	Superficie de la placa de cocción de mayor tamaño	Arealet af den største bageplade	Größe des größten Backblechs	Η μεγαλύτερη επιφάνεια ψησίματος εκφραζόμενη	The area of the largest baking sheet	Aire de la surface de la plus grande plaque pour pâtisserie	Superficie del piano di cottura più grande	Oppervlakte van de grootste bakplaat	Área da superfície da maior placa de pastelaria	Ytan för den största bakplåten	Suurimman leivinpellin ala	1130 cm ²
13	Ruido [dB (A) re 1 pW]	Lydeffektniveau dB (A) (Støj)	Geräusch (dB (A) re 1 pW)	Ξόρυβος [dB (A) ανά 1 pW]	Noise (dB (A) re 1 pW)	Bruit [dB (A) re 1 pW]	Rumore [dB (A) re 1 pW]	Geluidsniveau dB (A) re 1 pW	Nivel de ruído dB (A) re 1 pW	Bullernivå dB (A)	Ääni (dB (A) re 1 pW)	
	● Más eficiente Lavt forbrug Niedriger Verbrauch More efficient Économie	●●●●● Bassi consumi Efficient Mais efficace Låg förbrukning Vähän kuluttava	●●●●● Menos eficiente Højt forbrug Hoher Verbrauch Less efficient Peu économe	●●●●● Alti consumi Inefficient Menos eficiente Hög förbrukning Påjån kuluttava	●●●●● 12 l ≤Volumen neto/Nettovolumen/Ωφέλιμος όγκος/Usable volume/Volume utile/ Netto volume/Volume útil/Användbar volym/Käyttötilavuus < 35 l	●●●●● 35 l ≤Volumen neto/Nettovolumen/Ωφέλιμος όγκος/Usable volume/Volume utile/ Netto volume/Volume útil/Användbar volym/Käyttötilavuus < 65 l	●●●●● 65 l ≤Volumen neto/Nettovolumen/Ωφέλιμος όγκος/Usable volume/Volume utile/ Netto volume/Volume útil/Användbar volym/Käyttötilavuus	2002/40/EC				

John Lewis Partnership

171 Victoria Street

London SW1E 5NN

www.johnlewis.com