

# Motherboard 4S648/ 4S648N

1.1 Introduction .....	5
<b>1. 4S648/4S648N Specifications .....</b>	<b>5</b>
1.2 Package Contents .....	6
1.3 Specifications and Features .....	7
CPU Processor .....	7
Chipset .....	7
PCI .....	7
Integrated LAN Controller (for 4S648N only) .....	7
Universal Serial Bus .....	7
WOL (Wake On LAN) .....	7
Award BIOS .....	8
ATA 100/133 On Board .....	8
PCI-Based AC 97 Digital Audio Processor .....	8
AGP 4X/8X On Board .....	8
1.4 4S648/4S648N Layout Diagram .....	10
1.5 CPU and CPU Fan Installation .....	12
1.5.1 CPU Installation with Socket 478 .....	12
1.5.2 CPU Fan Installation with P4 Fan Base .....	13
1.6 DDR SDRAM Installation .....	14

- 1.7 Connectors & Jumpers Setting ..... 15**
  - 1.7.1 Back Panel I/O Connectors ..... 15**
    - 1.7.1.1 PS/2 Mouse / Keyboard CONN. .... 15
    - 1.7.1.2 USB Ports: USB1/2 ..... 15
    - 1.7.1.3 Serial Interface Port: COM1/COM2 ..... 16
    - 1.7.1.4 Parallel Interface Port ..... 16
    - 1.7.1.5 Audio Port Connectors ..... 16
  - 1.7.2 ATX Main Power Connectors: PW1/PW2 ..... 17**
  - 1.7.3 Floppy Disk Connector: FDD ..... 18**
  - 1.7.4 Hard Disk Connectors: IDE1/IDE2 ..... 18**
  - 1.7.5 Fan Connectors: FAN1~3 ..... 18**
  - 1.7.6 Audio-In Connectors: CD1/AUX In ..... 19**
  - 1.7.7 Wake On LAN Connector: WOL ..... 19**
  - 1.7.8 USB Pin Header: USB3 ..... 20**
  - 1.7.9 Front Panel Connectors: PANEL1 ..... 21**
  - 1.7.10 SPDIF Connector: SPDIF1 ..... 22**
  - 1.7.11 IR infrared module: IR1 Connector ..... 23**
  - 1.7.12 CMOS Function Selector: JP4 ..... 24**
  - 1.7.13 Keyboard/Mouse Wake-up selector: Jp5 ..... 24**
  - 1.7.14 USB2 Wake-up Selector: Jp11 ..... 25**
  - 1.7.15 USB3 Wake-up Selector : Jp10 ..... 25**
- 2. BIOS Setup ..... 26**
  - 2.1 BIOS Support ..... 26**
  - 2.2 Main Menu ..... 29**
  - 2.3 Standard CMOS Features ..... 32**
  - 2.4 Advanced BIOS Features ..... 36**

- 2.5 Advanced Chipset Features ..... 40**
- 2.6 Integrated Peripherals ..... 43**
- 2.7 Power Management Setup ..... 48**
- 2.8 PnP/PCI Configurations ..... 51**
- 2.9 PC Health Status ..... 54**
- 2.10 Frequency/Voltage Control..... 55**
- 2.11 Load Fail-Safe Defaults ..... 57**
- 2.12 Load Optimized Defaults ..... 58**
- 2.13 Set Supervisor / User Password ..... 59**
- 2.14 Save & Exit Setup..... 60**
- 2.15 Exit Without Saving ..... 61**
- 3. Drivers & Utilities ..... 62**
- 3.1 Auto-run Menu ..... 62**
- 3.2 Install Acceleration Graphics Driver ..... 64**
- 3.3 Installing SiS IDE PCI Driver ..... 65**
- 3.4 Install PCI LAN Driver (for 4S648N)..... 66**
- 3.4 Installing Audio Driver ..... 68**
- 3.4.1 Installing 6-channel Driver ..... 68**
- 3.4.2 Verifying 6-channel Driver ..... 68**
- 3.5 Installing USB 2.0 Driver ..... 70**



# Chapter 1

## 4S648/4S648N

## 1. 4S648/4S648N Specifications

### 1.1 Introduction

The 4S648/4S648N motherboard is an integration of Intel P4 CPUs in Socket-478 packaging and the North Bridge SiS648 supporting 533/400 MHz Front Side Bus.

North Bridge SiS648 on board also supports DDR 333/266/200 DRAMs and the integrated AGP 8X/4X Interface, while the South Bridge SiS963L provides stable supports of ULTRA ATA 133/100, 6-channel Audio playback, integrated Digital Audio Controller, LPC Super I/O, USB 2.0/1.1 interfac. PCI interface as well as integrated 10/100Mbit Fast Ethernet LAN Controller.

The resulting architecture will provide an ideal multi-task environment to support operating systems such as MS-DOS, Windows, Windows NT, Windows ME, Windows 2000, Novell, OS/2, Windows 95/98, Windows 98SE, Windows XP, UNIX, Liunx, SCO UNIX etc. This user-friendly manual is to describe in detail how to install, configure and use this motherboard with drivers and BIOS setup illustrations.

**This manual is a general reference of the first release of this motherboard which is subject to update without notice. If any difference is found between this manual and the motherboard you are using, please refer to the Web Site.**

## 1.2 Package Contents

- ◆HDD UDMA66/100 Cable.
- ◆FDD Cable.
- ◆Flash Memory with BIOS
- ◆Fully Setup Driver CD with built in utilities.
- ◆User Manual.
- ◆I/O Shielding.

## 1.3 Specifications and Features

### CPU Processor

- | Support 533/400MHz System Interface speed.
- | Single Socket 478 for Intel P4™ 1.5 to 3.06GHz or higher\* (Northwood Processor).
- | Support Intel Netburst™ Micro-architecture.

\* The higher frequency CPU should be compatible with Intel CPU specification and the motherboard latest BIOS version which will be released on the web site.

### Chipset

- | SiS648 North Bridge, supporting 533/400MHz FSB and AGP 2.0/3.0 interface
- | SiS963L South Bridge
- | Mutiol-link up to 1GHz

### PCI

- | Supports 33MHz PCI Bus speed.
- | 5 x PCI slots on board

### Integrated LAN Controller (for 4S648N only)

- | Supporting 10/100Mbit Fast Ethernet LAN
- | Supporting 1xRJ45 Connector (for 4S648N motherboard only)

### Universal Serial Bus

- | Supporting 4 on-board Universal Serial Bus(USB) Ports and 2 external Universal serial Bus(USB) Ports.
- | Supporting USB 2.0/1.1

### WOL (Wake On LAN)

- | Supporting system power-on by LAN Ring-up signal.

**Award BIOS**

- | Supporting Plug & Play specification which detects the peripheral devices and expansion cards automatically
- | Supporting CD-ROM, SCSI, LAN BOOT, Temperature sensor, LAN, Alarm Bus CLK setup
- | Supporting Desktop Management Interface (DMI) function for recording mainboard specification

**ATA 100/133 On Board**

- | Supporting four IDE devices with 2 x IDE connectors
- | Supporting PIO Mode 5, Master Mode, high performance hard disk drives
- | Dual -channel Ultra DMA 33/66/100/133 Bus Master Mode
- | Supporting IDE interface with CD-ROM
- | Supporting high capacity hard disk drives
- | Supporting LBA mode

**PCI-Based AC 97 Digital Audio Processor**

- | AC 97 2.2 compatible Codec, 6-channel Audio interface.
- | 18-bit Stereo Full-Duplex Codec with up to 48 KHz sampling rate
- | 4 Analog Line-level Stereo inputs for connection from Line, CD, Video and AUX
- | 2 Analog Line-level Stereo inputs for speakerphone and PC beep

**AGP 4X/8X On Board**

- | AGP 66MHz, 1.5V for AGP4X graphic card
- | 1 x AGP slot supported



# *Memo*

# 1.4 4S648/4S648N Layout Diagram

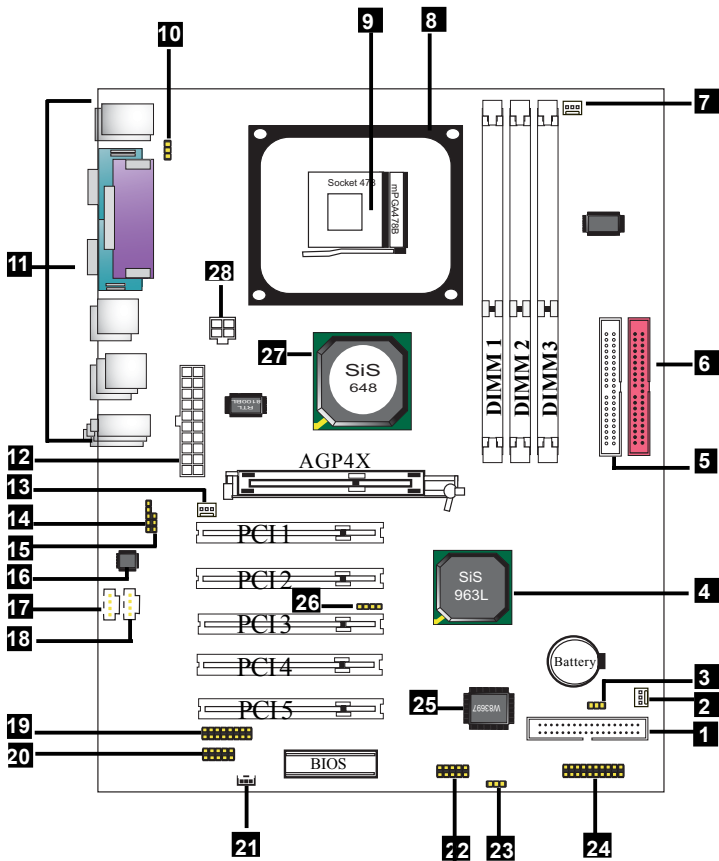

**4S648/4S648N Component Layout Description:**

- 1. FDC1: Floppy Drive Connector**
- 2. FAN3: Cooling Fan Connector**
- 3. JP4: Jumper for clearing CMOS select**
- 4. South Bridge SiS963L**
- 5. IDE1: IDE Connector**
- 6. IDE2: IDE Connector**
- 7. FAN1: CPU Cooling Fan Connector**
- 8. CPU Fan Base**
- 9. Socket 478 for P4 CPU**
- 10. JP5: Jumper for Keyboard/Mouse Wake-up function**
- 11. Back Panel: Back Panel I/O Connectors ( Mouse, Keyboard, COM1, COM2, Printer, USB2, USB1, Mic in, Line in, Speaker-out, RJ45 (for 4S648N motherboard only)**
- 12. ATX2: ATX Main Power Connector**
- 13. FAN2: Cooling Fan Connector**
- 14. SPDIF1: SPDIF S/P Digital Interface Format) Connector**
- 15. JP11: Jumper for USB2 Keyboard/Mouse Wake-up function**
- 16. Chip ALC650: Chip for AC'97 6-channel Audio Codec**
- 17. AUXIN1: Audio-in Connector**
- 18. CD1: Pin Header for CD Audio-in**
- 19. GAME1: Game Port**
- 20. IR1: Connector for Infrared signal transmission**
- 21. WOL1: Connector for Wake-on-LAN function**
- 22. USB3: Pin Header supporting 2 external USB Ports**
- 23. JP10: Jumper for USB3 Keyboard/Mouse Wake-up function**
- 24. Panel 1: Front Panel Connector**
- 25. IT8705F: LPC Super I/O Chip**
- 26. DEBUG1: Connector for Printer ERROR debug**
- 27. North Bridge SiS 648**
- 28. ATX2: +12V ATX Power Connector**

## 1.5 CPU and CPU Fan Installation

This motherboard is designed with Socket 478 for Intel P4™ processor.

### 1.5.1 CPU Installation with Socket 478

1. Pull the lever sideways away from the socket then raise the lever to a 90-degree angle.
2. Locate Pin 1 in the socket. Pin 1 of CPU is marked by the yellow corner or cut edge on the CPU. Match Pin 1 of Socket 478 and Pin 1 of CPU.
3. Pull up the lever of Socket 478 to let the CPU in and press the lever down to lock the CPU.
4. Make sure that Pin 1 of Socket 478 is matching with Pin 1 of CPU.
5. Make sure that all CPU pins are completely in socket before pressing down the socket lever.

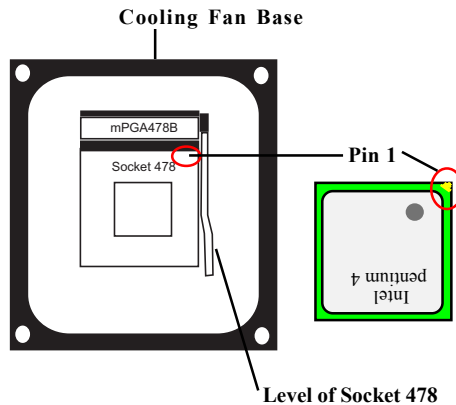

### 1.5.2 CPU Fan Installation with P4 Fan Base

1. P4 CPU Fan is typically designed with 4 latches and mounted with a thick heatsink. Please do not use other type of CPU fan which cannot match the P4 Fan base on board.
2. Install the P4 CPU fan into the Fan base in such a way that the 4 latches of the CPU Fan match with the 4 Supporters of the CPU Fan Base.
3. Press down the latches to lock CPU Fan to the Fan Base.
4. Then connect the Fan Power Cable to one of the Fan connectors on board.
5. Make sure that the Fan Power Cable is correctly connected to Fan Connector.

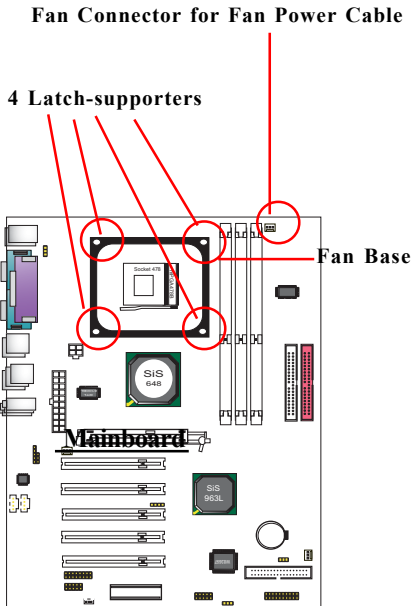

## 1.6 DDR SDRAM Installation

This motherboard supports a maximized 2GB DDR SDRAM. It provides two 184-pin unbuffered DDR sockets. It supports 64MB to 1GB DDR memory module.

### DDR SDRAM Installation Procedures:

1. The DDR socket has a “Plastic Safety Tab” and the DDR memory module has an asymmetrical notch”, so the DDR memory module can only fit into the slot in one direction.
2. Push the tabs out. Insert the DDR memory modules into the socket at a 90-degree angle then push down the module vertically to fit it into place.
3. The Mounting Holes and plastic tabs should fit over the edge and hold the DDR memory modules in place.

**Note: If you want to run FSB 533MHz on this Motherboard (with 133MHz CPU), you must use DDR 266MHz module because only DDR 266 is able to support FSB 533MHz.**

Bank	Memory module
DIMM 1	64MB, 128MB, 256MB, 512MB, 1GB
	184 pin, 2.5V DDR SDRAM
DIMM 2	64MB, 128MB, 256MB, 512MB, 1GB
	184 pin , 2.5V DDR SDRAM
	<b>Total System Memory (Max 2GB)</b>

184-pin DDR Module

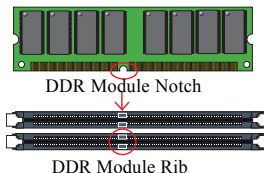

**Warning: Be sure to turn off system power whenever to insert or remove a Memory Module. Otherwise, the power will damage the module or even the system.**

## 1.7 Connectors & Jumpers Setting

### 1.7.1 Back Panel I/O Connectors

This motherboard provides the following back panel connectors:

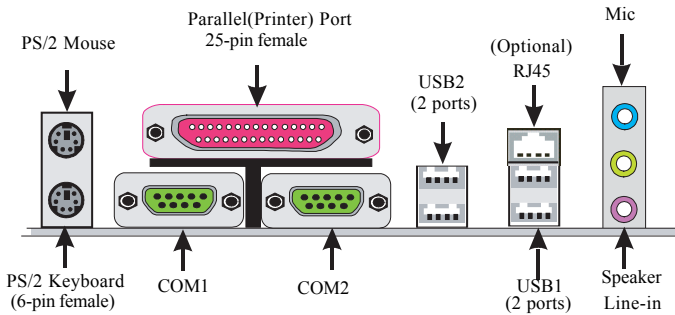

#### 1.7.1.1 PS/2 Mouse / Keyboard CONN.

The motherboard provides a standard PS/2 mouse / Keyboard mini DIN connector for attaching a PS/2 mouse. You can plug a PS/2 mouse / Keyboard directly into this connector.

#### 1.7.1.2 USB Ports: USB1/2

The motherboard provides a OHCI(Open Host Controller Interface)Universal Serial Bus Roots for attaching USB devices such as a keyboard, mouse and other USB devices. You can plug the USB devices directly into this connector.

### **1.7.1.3 Serial Interface Port: COM1/COM2**

The serial interface port is sometimes referred to as an RS-232 port or an asynchronous communication port. Mice, printers, modems and other peripheral devices can be connected to a serial port. The serial port can also be used to connect computer systems together. If you like to transfer the contents of your hard disk to another system, it can be accomplished with serial port.



### **1.7.1.4 Parallel Interface Port**

Unlike serial ports, parallel interface ports have been standardized and should not present any difficulty interfacing peripherals to your system. Sometimes called a Centronics port, the parallel port is almost exclusively used with printers. The parallel port on your system is a 25-pin, DB 25 connector.

### **1.7.1.5 Audio Port Connectors**

Speaker out is a connector for Speakers or Headphones. Line in is used for external CD player, Tape player, or other audio devices. Mic is a connector for the microphones.



### 1.7.2 ATX Main Power Connectors: PW1/PW2

This connector supports the power button on-board. Using the ATX power supply, functions such as Modem Ring Wake-Up and Soft Power Off are supported on this motherboard. This power connector supports instant power-on functionality, which means that the system will boot up instantly when the power connector is inserted on the board. ATX 4-pin power connector only support +12V voltage.



Pin PW1 Signal		Pin PW1 Signal	
1	GND	2	GND
3	+12V	4	+12V

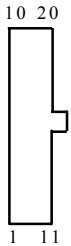

Pin PW2 Signal		Pin PW2 Signal	
1	3.3V	11	3.3V
2	3.3V	12	-12V
3	GND	13	GND
4	5V	14	PS-ON
5	GND	15	GND
6	5V	16	GND
7	GND	17	GND
8	PW-OK	18	-5V
9	5V <sub>SB</sub>	19	5V
10	12V	20	5V

**Note:**

When you set up P4 power supply, both PW1 and PW2 must be connected to power.

**Important:**

To switch on your power supply, please make sure:

1. Memory Module is properly installed.
2. Power supply setup is OK.

### 1.7.3 Floppy Disk Connector: FDD

This connector supports the provided floppy drive ribbon cable. After connecting the single end to the board, connect the two plugs on the other end to the floppy drives.

### 1.7.4 Hard Disk Connectors: IDE1/IDE2

These connectors are provided with IDE hard disk ribbon cable into the package . After connecting the end of cable with single connector to the mainboard, connect the other two connectors at the other end to your hard disk. If you install two hard disks, you must configure the second drive to Slave mode by setting its jumper settings. BIOS now supports SCSI device or IDE CD-ROM boot up (see "HDD Sequence SCSI/IDE First" & "Boot Sequence" in the BIOS Features Setup of the BIOS SOFTWARE).

### 1.7.5 Fan Connectors: FAN1~3

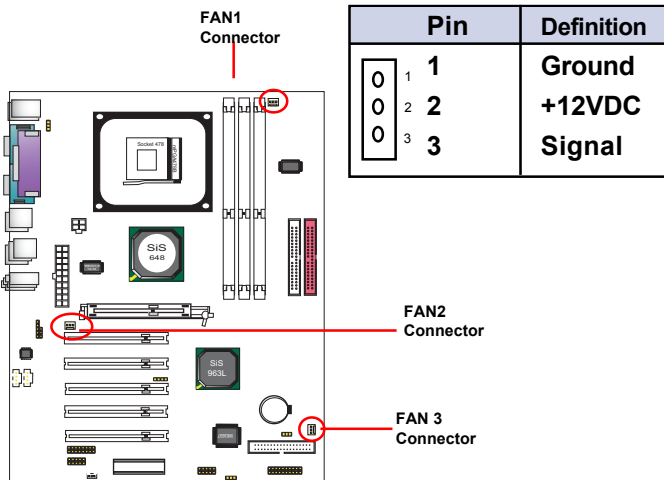

FAN1, FAN2 and FAN3 connectors

### 1.7.6 Audio-In Connectors: CD1/AUX In

CDIN1 and CDIN2 are the connectors for CD-Audio Input signal. Please connect them to CD-ROM CD-Audio output connector. CDIN1 and CDIN2 have the same pin assignment but different pin pitch.

Pin	CDIN1	Definition
1		CD-L
2		GND
3		GND
4		CD-R

Pin	AUX IN	Definition
1		AUX-L
2		GND
3		GND
4		AUX-R

### 1.7.7 Wake On LAN Connector: WOL

CN2 is an Wake On LAN (WOL) connector for transmitting the Ring signal from a PCI LAN card to wake up system. If you use a PCI LAN card for system networking, you can connect this Wake On LAN connector with the PCI LAN card on board for Wake On LAN function.

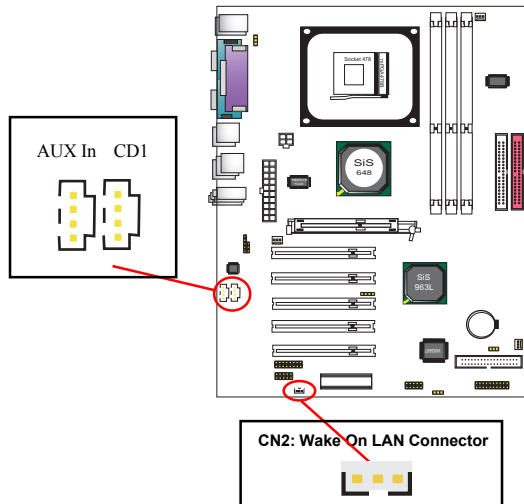

### 1.7.8 USB Pin Header: USB3

USB3 2x5 Pin Headers for support of external USB ports. Each USB pin header requires a USB cable for expansion of two USB ports. This optional USB cable is available from your motherboard dealer or vendor.

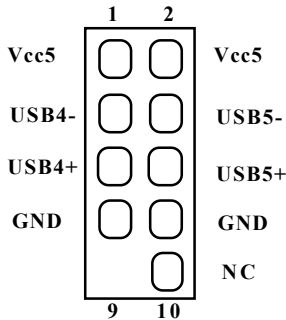
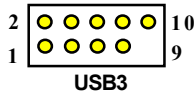
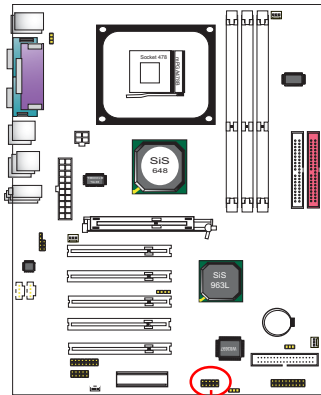

## 1.7.9 Front Panel Connectors: PANEL1

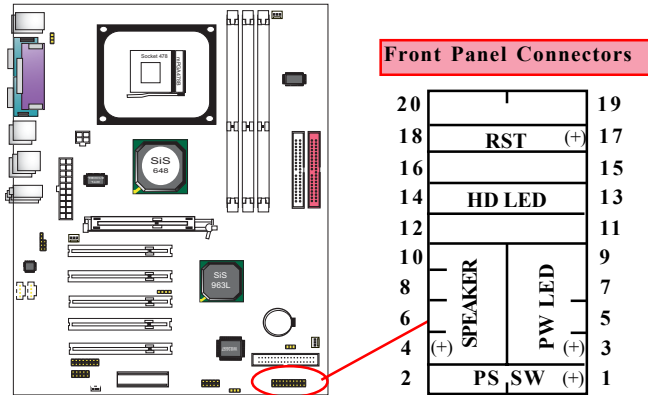

### PSSW

The system power is controlled by a momentary switch connected to this lead. Pushing the button once will switch the system ON.

### Power LED Lead (PW\_LED)

The system power LED lights when the system power is on.

### Speaker Connector (SPEAKER)

The speaker (onboard or offboard) provides error beep code information during the Power Self-Test when the computer cannot use the video interface. The speaker is not connected to the audio subsystem and does not receive output from the audio subsystem.

### Hard Drive LED Connector (HD\_LED)

This connector supplies power to the cabinet IDE activity LED. Read and write activity by devices connected to the Primary or Secondary IDE connectors will cause the LED to light up.

### SMI Suspend Switch Lead (G-BUN) (Disabled)

This allows the user to manually place the system into a suspend mode of Green mode. System activity will be instantly decreased to save electricity and expand the life of certain components when the system is not in use. This 2-pin connector (see the figure) connects to the case-mounted suspend switch. If you do not have a switch for the connector, you may use the "Turbo Switch" instead since it does not have a function. If you want to use this connector, the "Suspend Switch" in the Power Management Setup of the BIOS SOFTWARE section should be enabled.

### Reset Switch Lead (RST)

The connector can be connected to a reset switch. Press this reset switch to restart system.

## 1.7.10 SPDIF Connector: SPDIF1

SPDIF1 is designed on board for Digital Audio in/out.

SPDIF1

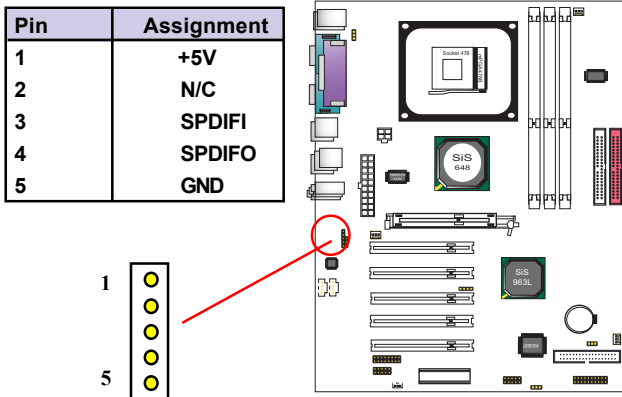

### 1.7.11 IR infrared module: IR1 Connector

This connector supports the optional wireless transmission and reception infrared module. You must configure the setting through the BIOS setup to use the IR function.

Pin	Assignment
6	NC
7	CIRRX
8	SB5V
9	GND
10	NC

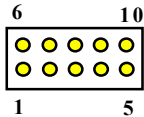

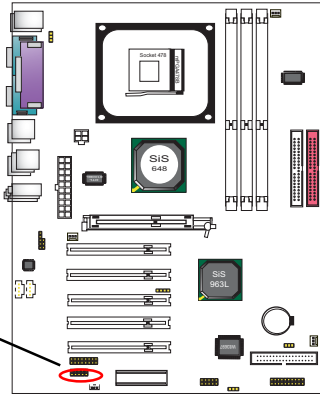

Pin	Assignment
1	+5V
2	N/C
3	IRRX
4	GND
5	IRTX

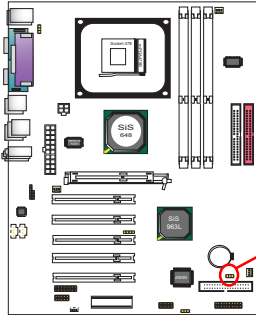

### 1.7.12 CMOS Function Selector: JP4

When you have problem with booting system, you may clear CMOS to restore the optimum default BIOS data.





Pin JP4	Function
1-2 closed 	Normal (Default)
2-3 closed 	Clear CMOS

1. Remove the Jumper cap of Jp5 from 1-2.
2. After 1 or two seconds, set Jp5 to 2-3 closed with the jumper cap.
3. After 1 or two seconds, restore the Jp5 to 1-2 closed.  
Now, the CMOS RAM has restored to the optimum default setting.

### 1.7.13 Keyboard/Mouse Wake-up selector: Jp5

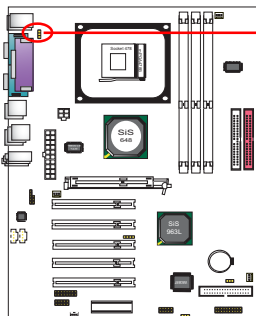
Jp5 is designed to wake up system by Keyboard/Mouse:





Pin Jp5	Function
2-3 closed 	Enabled
1-2 closed 	Disabled (default)

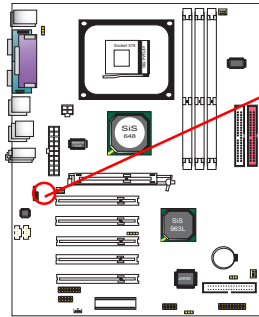

### 1.7.14 USB2 Wake-up Selector: Jp11

Jp11 is designed to select the USB2 wake up function:





Pin Jp11	Function
1-2 closed 	Disabled (Default)
2-3 closed 	Enabled

### 1.7.15 USB3 Wake-up Selector : Jp10

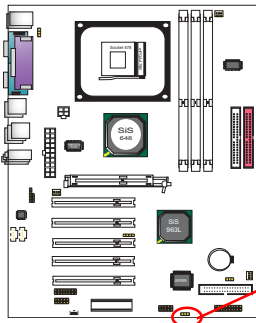
Jp10 is designed to select the USB1 wake up function:



Pin Jp10	Function
1-2 	Disabled (default)
2-3 	Enabled

# Chapter 2

## BIOS Setup

## 2. BIOS Setup

### 2.1 BIOS Support

This chapter discusses the Award BIOS Setup program built in the ROM BIOS. The Setup program allows the user to modify the basic system configuration. The modification is then stored in battery-backed RAM so that it can retain the setup information after the power is turned off. The Award BIOS installed in your computer system ROM (Read Only Memory) is a custom version of an industry standard BIOS. The BIOS provides critical low-level support for standard devices such as disk drives and serial and parallel ports. This chapter is intended for guiding you through the process of configuring your system BIOS.

#### **Plug and Play Support**

This AWARD BIOS supports the Plug and Play Version 1.0A specification. ESCD(Extended System Configuration Data) write is also supported.

#### **EPA Green PC Support**

This AWARD BIOS supports Version 1.03 of the EPA Green PC specification.

#### **PCI Bus Support**

This AWARD BIOS also supports Version 2.1 of the Intel PCI (Peripheral Component Interconnect) local bus specification.

### **APM Support**

This AWARD BIOS supports Version 1.1&1.2 of the Advanced Power Management(APM) specification. Power management features are implemented via the System Management Interrupt(SMI). Sleep and Suspend power management modes are supported. Power to the hard disk drives and video monitors can be managed by this AWARD BIOS.

### **DRAM Support**

DDR SDRAMs (Double Data Rate SDRAM) are supported.

### **CPU Support**

This AWARD BIOS supports the Intel P4 Processor.

### **Setup Menu**

In general, you use the arrow keys to highlight items of the Main BIOS Setup Menu, press <Enter> to select, use the <PgUp> and <PgDn> keys to change entries, press <F1> for help and press <Esc> to quit. The following table provides more detail about how to navigate in the Setup program by using the keyboard.

**Note:**

**(BIOS version 1.0 is for reference only. If there is a change in BIOS version, please use the actual version on the BIOS.)**

<b>Keystroke</b>	<b>Function</b>
Up arrow	Move to previous item
Down arrow	Move to next item
Left arrow	Move to the item on the left(menu bar)
Right arrow	Move to the item on the right(menu bar)
Esc	Main Menu: Quit without saving changes Submenus: Exit Current page to the next higher level menu
Move Enter	Move to item you desired
PgUp key	Increase the numeric value or make changes
PgDn key	Decrease the numeric value or make changes
+Key	Increase the numeric value or make changes
-Key	Decrease the numeric value or make changes
Esc Key	Main menu-Quit and not save changes into CMOS Status Page Setup Menu and option Page Setup Menu-Exit Current page and return to Main Menu
F1 Key	General help on Setup navigation keys.
F5 Key	Load previous values from CMOS
F6 Key	Load the fail-safe defaults from BIOS default table
F7 Key	Load the optimized defaults
F10 Key	Save all the CMOS changes and exit



**Standard CMOS Features**

This setup page includes all the items in standard compatible BIOS.

**Advanced BIOS Features**

This setup page includes all the items of the BIOS special enhanced features.

**Advanced Chipset Features**

This setup page includes all the items of the Chipset special enhanced features.

**Integrated Peripherals**

This selection page includes all the items of the IDE hard drive and Programmed Input/Output features.

**Power Management Setup**

This setup page includes all the items of the power management features.

**PnP/PCI Configurations**

This setup page includes the user defined or default IRQ Setting.

**PC Health Status**

This page shows the hardware Monitor information of the system.

**Frequency/Voltage Control**

This setup page controls the CPU's clock and frequency ratio.

**Load Fail-safe Defaults**

Use this menu to load the BIOS default values for the minimal/stable performance for your system to operate.

**Load Optimized Defaults**

These settings are for configuring a workable computer when something is wrong. If you cannot boot the computer successfully, select the BIOS Setup options and try to diagnose the problem after the computer boots. These settings do not provide optional performance.

**Set Supervisor/User Password**

Change, set, or, disable password. It allows you to limit access to the system and Setup, or just to Setup.

**Save & Exit Setup**

Save CMOS value changes to CMOS and exit setup.

**Exit Without Saving**

Abandon all CMOS value changes and exit setup.

## 2.3 Standard CMOS Features

This main option in the Standard CMOS Setup Menu is divided into 10 fields or items. Each field provides one or more setup choices. Use the arrow keys to highlight the field and then use the <PgUp> or <PgDn> keys to select the value or choice.

### Phoenix - AwardBIOS CMOS Setup Utility Standard CMOS Features

Date(mm:dd:yy)	Tue,Jun 6 2002	Item Help
Time (hh:mm:ss)	11:26:10	
IDE Primary Master	None	Menu Level
IDE Primary Slave		Change the day, month,year and century.
IDE Secondary Master		
IDE Secondary Master	None	
Drive A	1.44M,3.5 in	
Drive B	None	
Floppy 3	Disabled	
Video	EGA/VGA	
Halt On	All,But Keyboard	
Base Memory	640K	
Extended Memory	65472K	
Total	1024K	

←→↑↓: Move Enter:Select +/-/PU/PD:Value F10:Save ESC:Exit F1:General Help  
F5:Previous Values F6:Fail-Safe Defaults F7:Optimized Defaults



**Main Menu Selections**

<b>Item</b>	<b>Options</b>	<b>Description</b>
Date (mm : dd :yy)	Month Day Year	Set the system,date. Note that the 'Day' automatically changes when you set the data.
Time (hh : mm : SS)	Hour Minute Second	Select the hour, minute and second of the time.
IDE Primary Master	Options are in its sub menu.	Press<Enter> to enter sub menu.
IDE Primary/ Slave	Options are in its sub menu.	Press<Enter> to enter sub menu.
IDE Second- ary Master	Options are in its sub menu.	Press<Enter> to enter sub menu.
IDE Second- ary Slave	Options are in its sub menu.	Press<Enter> to enter sub menu
Drive A Drive B	None 360K,5.25in, 1.2M,5.25in 720K,3.5M 1.44M,3.5in 2.88M,3.5in	Select the type of floppy disk drive installed in your system.
Floppy 3 Mode Support	Disabled Driver A Driver B Both	Disable or support the 3rd floppy mode in Drive A, or Drive B or both.
Video	EGA/VGA CGA 40 CGA 80 MONO	Select the default video device.

Item	Options	Description
Halt On	All Errors No Errors All, but Keyboard All, but Diskette All, but Disk/Key	Select the situation in which you want the BIOS to stop the POST process and notify.
Base Memory	(640K)	The amount of conventional memory detected during boot up.
Extended Memory	( 65472K )	The amount of conventional memory detected during boot up.
Total Memory	( 1024K )	The total memory available in system.

**IDE Primary(Master/Slave)/Secondary(Master/Slave)**

Press Enter on these items to show the following sub-menu:

Primary Master/Secondary

IDE HDD Auto-Detection	Press Enter Item Help	
IDE Primary Master	Auto	Menu Level
Access Mode	Auto	
Capacity	13022MB	
Cylinder	25232	
Head	16	
Precomp	0	
Landing Zone	25231	
Sector	61	

←→↑↓: Move Enter:Select +/-/PU/PD:Value F10:Save ESC:Exit F1:General Help  
F5:Previous Values F6:Fail-Safe Defaults F7:Optimized Defaults

**IDE HDD Auto-Detection**

Press Enter on this item to let BIOS auto-detect your Hard Disk and show all the Primary Hard Disk Parameters ( Capacity, Cylinder, Head, Precomp, Landing Zone, Sector) on the menu.

**IDE Primary(Master/Slave)/Secondary(Master/Slave)**

This item allows you to detect the Hard Disk in 3 ways.

- The Choices: Auto: BIOS Auto-detect HDD;
- None: No Hard Disk detected;
- Manual: Manually detect HDD

**Access Mode**

This item allows you to select the Access mode to the Hard Disk..

The Choices:

- CHS: Select the Cylinder, Head, Sector addressing mode to access Hard Disk;
- LBA: Select the Logical Block Addressing mode to access Hard Disk.
- Large: Select Large Mode to access Hard Disk;
- Auto: Allow BIOS to auto-access Hard Disk;

**Capacity**

Showing the capacity of Hard Disk in MB.

**Cylinder**

Showing the number of cylinder in the Hard Disk.

**Head**

Showing the number of heads in the Hard Disk.

**Precomp**

The number of Pre-compensation.

**Landing Zone**

Number of Landing zone in the Hard Disk.

**Sector**

The number of Sector in the Hard Disk.

## 2.4 Advanced BIOS Features

### Phoenix - AwardBIOS CMOS Setup Utility Advanced BIOS Features

Virus Warning	Disabled	Item Help
CPU L1 & L2 Cache	Enabled	
Quick Power On Self Test	Enabled	
First Boot Device	Floppy	
Second Boot Device	HDD-0	
Third Boot Device	LS-120	
Boot Other Device	Enabled	
Swap Floppy Drive	Disabled	
Boot Up Floppy Seek	Disabled	
Boot Up NumLock Status	On	
Gate A20 Option	Fast	
Typematic Rate Setting	Disabled	
X Typematic Rate (Chars/Sec)	6	
X Typematic Delay (Msec)	250	
Security Option	Setup	
APIC Mode	Disabled	
x MPS Version Control For OS	1.4	
OS Select For DRAM >64MB	Non-OS2	
HDD S.M.A.R.T. Capability	Disabled	
Report No FDD for Win95	No	
Video BIOS Shadow	Enabled	
EPA / (H/W Monitor) Show	EPA Logo	

←→↑↓: Move Enter:Select +/-/PU/PD:Value F10:Save ESC:Exit F1:General Help  
F5:Previous Values F6:Fail-Safe Defaults F7:Optimized Defaults

#### Virus Warning

This option allows you to choose the VIRUS Warning feature for IDE Hard Disk boot sector protection. If this function is enabled and someone attempts to write data into this area, BIOS will show a warning message on screen and alarm beep.

The Choices:

Disabled(default), Enabled.

**CPU L1 & L2 Cache**

These fields allow you to Enable or Disable the CPU's L1 (Internal) / L2 (External) cache to provide better performance.

The choices:

Enabled (default); Disabled

**Quick Power On Self Test**

This category speeds up Power on self-Test (POST) after you power up the computer. If it is set to Enabled, BIOS will shorten or skip some check items during POST.

The choices:

Enabled (default); Disabled

**First/Secondary/Third Boot Device**

This BIOS attempts to load the operating system from the devices in the sequence selected in these items.

The Choices:

Floppy (default), LS120, HDD-0, SCSI, CDROM, HDD-1, HDD-2, HDD-3, ZIP100, LAN, USB-FDD, USB-Zip, USB-CDROM, USB-HDD, Disabled.

**Boot Other Device**

Allows user to set booting from other devices.

The Choices:

Enabled (default), Disabled.

**Swap Floppy Drive**

If the system has two floppy drives, you can swap the logical drive name assignments.

The Choices:

Disabled (default), Enabled.

**Boot Up Floppy Seek**

If enabled, this item allows BIOS to test floppy drives to determine whether they have 40 or 80 tracks.

The Choices:

Disabled (default), Enabled.

**Boot Up NumLock Status**

Select power on state for Numlock..

The Choices

On (default): Numpad is number keys;

Off: Numpad is arrow keys;

**Gate A20 Option**

Select if chipset or keyboard controller should control Gate A20.

The choices:

Normal: A pin in the keyboard controller controls Gate A20.

Fast (default): Lets chipset control Gate A20.

**Typematic Rate Setting**

Allows user to adjust the key stroke repeat rate.

The choices:

Enabled: Enabled this option to adjust the keystroke repeat rate; Disabled (default): Disabled.

**Typematic Rate (Char/Sec)**

Range between 6(**default**) and 30 characters per second. This option controls the speed of repeating keystrokes.

**Typematic Delay (Msec)**

This option sets the time interval for displaying the first and the second characters.

The Choices: 250(default), 500, 750, 1000.

**Security Option**

This category allows you to determine whether to use password access the system and Setup, or just Setup.

The choices:

System: To access system and BIOS Setup with correct password.

Setup (default): To access BIOS Setup with correct password.

**APICMode**

Allows user to disable/enable the APIC mode  
The Choices: Disabled; Enabled

**x MPS Version Control For OS**

If APIC mode is enabled, this item allows user to select the MPS Version Control For OS.  
The choices: 1.4; 1.1

**OS Select For DRAM >64MB**

Select the operating system that is running with greater than 64MB of RAM on the system.  
The Choices: Non-OS2(default), OS2.

**HDDS.M.A.R.T.Capability**

Allows user to choose the Self-monitoring Analysis and Reporting Technology for Hard Disk Drive.  
The choices: Disabled(default); Enabled

**Report No FDD for Win 95**

Use this item to report no FDD for Win 95.  
The choices: No; Yes

**Video BIOS Shadow**

Use this item to enable/disable the Video BIOS Shadow function  
The choices: Enabled; Disabled

**EPA/(H/W Monitor) Show**

Use this item to enable/disable the Environmental Protection Association (EPA)/ Hardware Monitor) logo on initiating screen..  
The choices: H/W Monitor; EPA Logo

## 2.5 Advanced Chipset Features

This section allows you to configure the system based features of the installed chipset. This chipset manages bus speeds and access to system memory resources, such as DRAM and external cache. It also coordinates communications of the PCI bus. It must be stated that these items should never be altered. The default settings are set up to provide the best operating conditions for your system. The time you might need to make any changes would be if you discover that data is lost while using your system.

Phoenix - AwardBIOS CMOS Setup Utility  
Advanced Chipset Features

<ul style="list-style-type: none"> <li>▶ DRAM Clock/Timing Control      Press Enter</li> <li>  DRAM Timing Control            By SPD</li> <li>  x DRAM CAS Latency              2.5T</li> <li>  x RAS Active Time                6T</li> <li>  x RAS Precharge Time            3T</li> <li>  x RAS to CAS Delay (tRCD)      3T</li> <li>  DRAM Addr/Cmd Rate</li> </ul>	Item Help
<ul style="list-style-type: none"> <li>▶ AGP &amp; P2P Bridge Control      Press Enter</li> <li>  AGP Aperture Size                64MB</li> <li>  Graphic Window WR Combin      Disabled</li> </ul>	
<ul style="list-style-type: none"> <li>Prefetch Caching                  Disabled</li> <li>System BIOS Cacheable            Enabled</li> <li>Video RAM Cacheable              Enabled</li> <li>Memory Hole at 15M-16M          Disabled</li> </ul>	

←→↑↓: Move    Enter:Select    +/-/PU/PD:Value    F10:Save    ESC:Exit    F1:General Help  
 F5:Previous Values    F6:Fail-Safe Defaults    F7:Optimized Defaults



**> DRAM Clock/Timing Control: Press <Enter> to reveal the following submenu.**

**DRAM Timing Control**

Use this item to select the DRAM Clock/Timing mode.

The Choices:

By SPD: DRAM Timing is by Serial Presence Detect (SPD) which is located on the memory module itself.

Manual: DRAM Timing is set manually with the options following this item below.

**X DRAM CAS Latency**

This item is to set CAS (Column Access Stroke) Latency time.

The Choices: Auto; 1.5; 2; 2.5;

**X RAS Active ,Time**

This item is to set Active to Precharge Delay cycle.

The Choices: Auto; 7; 6; 5

**X DRAM RAS# to CAS# Delay (tRCD)**

This item is to set the DRAM RAS (Row Access Stroke) to CAS (Column Access Stroke) Delay cycle.

The Choices: Auto; 3; 2

**X DRAM RAS# Precharge**

This item is to set the DRAM RAS Precharge cycle.

The Choices: Auto; 3; 2

**DRAMAddr/CmdRate**

This item is to set the DRAM Addr/Command rate.

The Choices: Auto; 1T; 2T

> **AGP & P2P BBridge Control:** Press <Enter> to reveal the following submenu.

**AGP Aperture Size**

Select the size of the Accelerated Graphic Port(AGP) aperture . The aperture is a portion of the PCI memory address range dedicated for graphics memory address space. Host cycle that hit the aperture range are forwarded to the AGP without any translation.

The Choices: 128MB(default); 64MB;32MB; 16MB; 8MB; 4MB;256MB

**Graphic Window WR Combin**

Use this item to enable/disable the Graphic Window Write Combin function.

The choices: Enabled; Disabled

**Prefetch Caching**

This item is to enable/disable the Prefetch Caching function.

The Choices: Enabled , Disabled.

**System BIOS Cacheable**

This item is to enable/disable the System BIOS Cacheable function.

**Video RAM Cacheable**

Enabled: Enable Video RAM Cacheable.

Disabled :Disable Video RAM Cacheable.

**Memory Hole At 15-16M**

In order to improve performace, certain space in memory can be reserved for ISA cards. This memory must be mapped into the memory's space below 16MB.

The Choices: Disabled; Enabled.

## 2.6 Integrated Peripherals

### Phoenix - AwardBIOS CMOS Setup Utility Integrated Peripherals

		Item Help
▶ SiS OnChip IDE Device      Press Enter		
Internal PCI/IDE	Both	
IDE Primary Master PIO	Auto	
IDE Primary Slave PIO	Auto	
IDE Secondary Master PIO	Auto	
IDE Secondary Slave PIO	Auto	
IDE Primary Master UDMA	Auto	
IDE Primary Slave UDMA	Auto	
IDE Secondary Master UDMA	Auto	
IDE Secondary Slave UDMA	Auto	
IDE Burst Mode	Enabled	
▶ SiS OnChip PCI Device      Press Enter		
SiS USB Controller	Enabled	
USB 2.0 Controller	Enabled	
USB Keyboard Support	Disabled	
SiS AC97 Audio	Auto	
SiS S/W Modem	Auto	
SiS 10/100M Ethernet(4S648N)	Enabled	
▶ Onboard Super IO Device      Press Enter		
Onboard FDC Controller	Enabled	
Onboard Serial Port 1	3F8/IRQ4	
Onboard Serial Port 2	2F8/IRQ3	
UART Mode Select	Normal	
x UR2 Duplex Mode	Half	
Onboard Parallel Port	378/IRQ7	
Parallel Port Mode	ECP	
ECP Mode Use DMA	3	
Game Port Address	201	
MIDI Port Address	330	
MIDI Port IRQ	10	
IDE HDD Block Mode	Enabled	
Init Display First	PCI Slot	

←→↑↓: Move    Enter:Select    +/-/PU/PD:Value    F10:Save    ESC:Exit    F1:General Help  
F5:Previous Values    F6:Fail-Safe Defaults    F7:Optimized Defaults

**SiS On-Chip IDE Device: Press Enter to configure the following submenu:**

**Internal PCI/IDE**

Use this item to choose the ePCI/IDE mode.

The choices: Both; Disabled; Primary; Secondary

**IDE Primary Master/Slave PIO**

Auto (default):BIOS will automatically detect the IDE HDD Accessing mode.

Mode 0~4: Manually set the IDE Accessing mode.

**IDE Secondary Master/Slave PIO**

Auto (default):BIOS will automatically detect the IDE HDD Accessing mode.

Mode 0~4: Manually set the IDE Accessing mode.

**IDE Primary Master/Slave UDMA**

Auto (default):BIOS will automatically enable Ultra DMA mode of the IDE HDD Accessing .

Disabled: UDMA mode is disabled

**IDE Secondary Master/Slave UDMA**

Auto (default):BIOS will automatically enable the Ultra DMA mode of the IDE HDD Accessing mode.

Disabled: Ultra DMA disabled.

**IDE Burst Mode**

Use this item to enable/disable the IDE Burst mode.

**SiS On-Chip PCI Device: Press Enter to configure the following submenu:**

**SiS USB Controller**

Use this item to enable or disable the USB Controller.

**USB 2.0 Controller**

The Choices: Enabled (default); Disabled

If USB Controller is enabled, use this item to enable or disable USB 2.0 controller.

The Choices: Enabled (default); Disabled

**USB Keyboard Support**

If USB Controller is enabled, use this item to enable or disable the USB Keyboard Support.

The Choices: Enabled (default); Disabled

**SiS AC97 Audio / S/W Modem**

Use this item to enable/disable the AC97 Audio/ SW Modem function.

The Choices: Enabled; Disabled

**SiS 10/100M ETHERNET (for 4S648N only)**

Use this item to enable or disable the 10/100 Ethernet controller.

The Choices: Enabled; Disabled

**Onboard Super IO Device: Press Enter to configure the following submenu:**

**Onboard FDC Controller**

The choices: Enabled (default) Disabled

**Onboard Serial Port 1/2**

Select an address and corresponding interrupt for the first and second serial ports.

The Choices: Auto; 3F8/IRQ4; 2F8/IRQ3; 3E8/IRQ4; 2E8/IRQ3; Disabled.

**UART Mode Select**

This item allows you to select which Infra Red(IR) function of the onboard I/O chip you wish to use.

The Choices: Normal(default), IrDA, SCR, ASKIR.

**UR2 Duplex Mode**

This item allows you to select which Infra Red(IR) function of the onboard I/O chip you wish to use.

The Choices: Half (default), Full.

**Onboard Parallel Port**

This item allows you to select the onboard parallel port and IRQ.

The Choices: 378/IRQ7; 278/IRQ5; 3BC/IRQ7; Disabled

**Parallel Port Mode**

The choices are for Parallel Port Mode select:

The choices: SPP; EP; ECP; ECP+EPP

**ECP Mode Use DMA**

The Choices: 3(default), 1.

**Game Port Address**

The choices are for setting Game Port Address:

201 (default); 209; Disabled

**MIDI Port Address**

The choices are for setting MIDI Port Address:

300; 330 (default); Disabled.

**MIDI Port IRQ**

The choices are for setting MIDI Port IRQ:

10 (default); 5

**IDE HDD Block Mode**

If your IDE HDD supports block mode select, enabled is for automatic detection of the optimal number of block read/write per sector the drive can support..

The Choices: Enabled(default); Disabled

**Init Display First**

Use this item to enable or disable the onboard USB controller.

The Choices: PCI Slot(default); Onboard/ AGP

## 2.7 Power Management Setup

Phoenix - AwardBIOS CMOS Setup Utility

### Power Management Setup

		Item Help
ACPI Function	Enabled	
ACPI Suspend Type	S1(POS)	
Power Management	User Define	
Suspend Mode	Disabled	
Video Off Option	Suspend --> Off	
Video Off Method	V/H Sync+Blank	
Modem Use IRQ	3	
Hot Key Function As	Power Off	
HDD Off After	Disabled	
Power Button Override	Instant-off	
▶ PM Wake Up Events	Press Enter	
Power On By Modem Ring	Disabled	
Power On By MAC	Disabled	
Power On by PME/WOL	Disabled	
Power On By USB	Disabled	
Power On by PS/2KB	Password	
X Power On by PS2MS	Disabled	
RTC Alarm Resume	Disabled	
X Month Alarm	NA	
\X Date (of Month) Alarm	0	
X Time(hh:mm:ss) Alarm	0 : 0 : 0	
** Reload Global Timer Events **		
Primary IDE	Disabled	
Secondary IDE	Disabled	
FDD,COM, LPT Port	Disabled	
PCI PIRQ [A-D]#	Disabled	
Delay Prior to Thermal	None	

←→↑↓: Move Enter:Select +/-/PU/PD:Value F10:Save ESC:Exit F1:General Help  
 F5:Previous Values F6:Fail-Safe Defaults F7:Optimized Defaults

### ACPI Function

The choices are for enabling or disabling the Advanced Configuration and Power Management (ACPI).



**ACPI Function**

Use this item to enable/disable the ACPI function.  
The choices: Stop Grant(default); Power On Suspend

**ACPI Suspend Type**

The choices are for setting the ACPI Suspend Type.  
S1(Power On Suspend)(default); S3(Suspend To RAM); S1&S3

**Power Management**

The choices are for setting the Power management mode:  
User Define (default); Min Saving; Max Saving.

**Suspend Mode**

Use this item to set the Suspend time.  
The choices: Disabled(default); 1~60 min.

**Video Off Option**

The choices are for setting the Video Off option:  
Suspend --> Off; Susp, Stby --> Off; All Modes --> Off;  
Always On

**Video Off Method**

The choices are for determining the manner in which the monitor is blanked.  
The choices:  
V/H SYNC+Blank (default): Turn off the vertical and horizontal synchronization ports and write blanks to the video buffer.  
Blank Screen: Writes blanks to the video buffer.  
DPMS Supported: Initial display power management signaling.

**Modem Use IRQ**

This determines the IRQ, which can be applied in Modem use.  
The choices: 3 (default); 4;5; 7; 9; 10; 11; NA

**Hot Key Function As**

Use this item to set the Hot Key Function.  
The choices: Disabled; Power Off; Suspend

**HDD Off After**

Use this item to set the HDD Off After time.  
The choices: Disabled; 1~15 min..

**Power Button Override**

Use this item to set the Power Button Override mode  
The Choices: Instant off(; Delay 4 Sec.

**> PM Wake Up Events: Press <Enter> to configure the following:**

**Power On By Modem Ring**

Use this item to enable/disable the Power On by Modem Ring signal.

**Power On By MAC**

Use this item to enable/disable the Power On by MAC function.

**Power On By PME/WOL**

Use this item to enable/disable the Power On by PME/WOL function.

**Power On By USB**

Use this item to enable/disable the Power On by USB function..

**Power On By PS/2 KB**

Use this item to enable/disable the Power On by PS/2 Keyboard function.

**x Power On By PS/2 MS**

Use this item to enable/disable the Power On by PS/2 Mouse.

**RTC Alarm Resume**

Use this item to enable/disable the RTC Alarm Resume function.  
Date: If RTC Alarm Resume is enabled, set the date with this item.  
Time: If RTC Alarm Resume is enabled, set the time with this item.

**\*\* Reload Global Timer Events \*\***

**Primary IDE**

Use this item to enable/disable the Primary IDE

**Secondary IDE**

Use this item to enable/duisable the Secondary IDE.

**FDD,COM,LPTPort**

Use this item to enable/disable the HDD/COM/LPT port.

**PCIPIRQ[A-D]#**

Use this item to enable/disable the PCI PIRQ [A-D].

**Delay Prior to Thermal**

Use this item to set the Delay time prior to thermal.  
The choices: None; 1min; 2min; 4min; 8min; 16min; 32min; 64min

## 2.8 PnP/PCI Configurations

This section describes configuration of the PCI bus system. PCI or Personal Computer Interconnect, is a system which allows I/O devices to operate at speeds nearing the speed of the CPU itself when communicating with the components on board. This section covers some very technical items and it is strongly recommended that only experienced users should make any changes to the default settings.

### Phoenix - AwardBIOS CMOS Setup Utility PnP/PCI Configurations

Reset Configuration Data	Disabled	Item Help
Resources Controlled By x IRQ Resources	Auto(ESCD) Press Enter	
PCI/VGA Palette Snoop	Disabled	

←→↑↓: Move Enter:Select +/-/PU/PD:Value F10:Save ESC:Exit F1:General Help  
F5:Previous Values F6:Fail-Safe Defaults F7:Optimized Defaults

**Reset Configuration Data**

The system BIOS supports the PnP feature so the system needs to record which resource is assigned and proceeds to get rid of resource conflict. Every peripheral device has a node, which is called ESCD (Extended System Configuration Data). This node records which resources are assigned to it. If Disabled (Default) is chosen, the system ESCD will update only when the new configuration varies from the last one. If Enabled is chosen, the system is forced to update ESCDs and then is automatically reset to the “Disabled” mode.

**Resources Controlled By**

By Choosing “Auto”(default), the system BIOS will detect the system resources and automatically assign the relative IRQ and DMA channel for each peripheral. By choosing “Manual”, the user will need to assign IRQ & DMA for add-on cards. Be sure that no IRQ/DMA and I/O port conflict exists.

**IRQ Resources :**

Press Enter to configure the following Submenus

**IRQ Resources**

		Item Help
IRQ-3 assigned to	: PCI Device	
IRQ-4 assigned to	: PCI Device	
IRQ-5 assigned to	: PCI Device	
IRQ-7 assigned to	: PCI Device	
IRQ-9 assigned to	: PCI Device	
IRQ-10 assigned to	: PCI Device	
IRQ-11 assigned to	: PCI Device	
IRQ-12 assigned to	: PCI Device	
IRQ-14 assigned to	: PCI Device	
IRQ-15 assigned to	: PCI Device	

←→↑↓: Move    Enter:Select    +/-/PU/PD:Value    F10:Save    ESC:Exit    F1:General Help  
 F5:Previous Values    F6:Fail-Safe Defaults    F7:Optimized Defaults

**IRQ Resources**

When resources are controlled manually, assign each system interrupt a type, depending on the type of device using the interrupt.

**PCI/VGA Palette Snoop**

Choose Disabled or Enabled. Some graphic controllers which are not VGA compatible take the output from a VGA controller and map it to their display as a way to provide boot information and VGA compatibility.

However, the color information coming from the VGA controller is drawn from the palette table inside the VGA controller to generate the proper colors, and the graphic controller needs to know what is in the palette of the VGA controller. To do this, the non-VGA graphic controller watches for the write access to the VGA palette and registers the snoop data. In PCI based systems, the Write Access to the palette will not show up on the ISA bus if the PCI VGA controller responds to the Write.

In this case, the PCI VGA controller should not respond to the Write, it should only snoop the data and permit the access to be forwarded to the ISA bus. The non-VGA ISA graphic controller can then snoop the data on the ISA bus. Unless you have the above situation, you should disable this option.

The choices: Disabled (default); Enabled

## 2.9 PC Health Status

Phoenix - AwardBIOS CMOS Setup Utility

### PC Health Status

	Item Help
Vcore	
Vcc 3.3V	
Vcc 5.0V	
Vcc 12.0V	
Vsb 5.0V	
Voltage Battery	
CPU Temperature	
System Temperature	
Fan 1 Speed	
Fan 2 Speed	
Fan 3 Speed	

←→↑↓: Move Enter:Select +/-/PU/PD:Value F10:Save ESC:Exit F1:General Help  
F5:Previous Values F6:Fail-Safe Defaults F7:Optimized Defaults

This menu shows the current status of the system, CPU and CPU Fan. No value in this menu can be changed manually.

#### **Vcore /+3.3V/+5V/12V/5Vsb**

These items show the respective voltage running on board.

#### **Voltage Battery**

These items show the battery voltage used on board.

#### **CPU/System Temp**

This item shows the current System/CPU temperature.

#### **FAN1/2/3 Speed**

This item shows the fan speed running on board.

## 2.10 Frequency/Voltage Control

### Phoenix - AwardBIOS CMOS Setup Utility Frequency/Voltage Control

		Item Help
Auto Detect PCI CLK	Enabled	
Spread Spectrum	Disabled	
CPU Clock	100	
CPU0 Skew Adjust	Disabled	
CPU1 Skew Adjust	Disabled	
DRAM Skew Adjust	Disabled	
AGP Skew Adjust	500ps	
PCI0 Skew Adjust	Disabled	
PCI1 Skew Adjust	Disabled	
ZClk Skew Adjust	Dsiabled	
Buffer In Skew Adjust	Disabled	
FeedBack In Skew Adjust	900ps	
CPU:DRAM Frequency Ratio	SPD	
DRAM Frequency	133 MHz	
DDR Voltage Regulator	2.5V	

←→↑↓: Move Enter:Select +/-/PU/PD:Value F10:Save ESC:Exit F1:General Help  
F5:Previous Values F6:Fail-Safe Defaults F7:Optimized Defaults

#### Auto Detect PCI CLK

This item allows you to enable/disable auto detect PCI CLOCK.  
The Choices: Disabled; Enabled (default)

#### Spread Spectrum

This function is designed for the EMI test only.  
The Choices: Disabled(default); +/- 0.25; +/- 0.35; +/- 0.45; -0.5

#### CPU Clock

Use this item to set CPU Clock .  
The Choices: 100~132 MHz in 1MHz stepping

#### CPU 0/1 Skew Adjust

Use this item to enable/disable the CPU skew adjust function.

#### DRAMSkew Adjust

Use this item to enable/disable the DRAM Skew Adjust function.

**AGP Skew Adjust**

Use this item to reset the AGP skew adjust function.  
The choices: 500ps; 100ps; 1500ps; Disabled

**PCI0/1 Skew Adjust**

Use this item to enable/disable the PCI Skew Adjust function.

**ZClk Skew Adjust**

Use this item to enable/disable the ZClk skew adjust function.

**Buffer In Skew Adjust**

Use this item to enable/disable the Buffer In Skew Adjust function.

**Feedback In Skew Adjust**

Use this item to enable/disable the Feedback In Skew Adjust function.  
The choices: 900ps; 600ps; 300ps; Disabled

**CPU:DRAM Frequency Ratio**

Use this item to set the CPU:DRAM Frequency Ratio.  
The choices: 1:1; 1:2; 3:4; 3:5

**xDRAM Frequency**

This item will show the DRAM Frequency with the CPU:DRAM frequency Ratio.

**DDR Voltage Regulator**

Use this item to adjust the DDR Voltage.  
The Choices: 2.5V; 2.7V; 2.9V





## 2.12 Load Optimized Defaults

When you press <Enter> on this item, you get a confirmation dialog box with a message similar to:

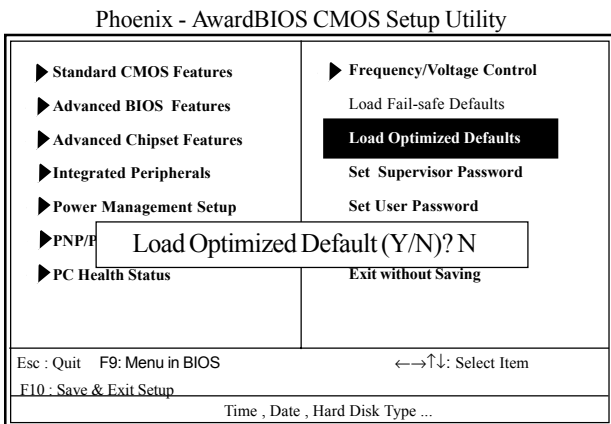

Pressing ‘Y’ loads the default values that are factory settings for optimal performance of system operations.



## 2.14 Save & Exit Setup

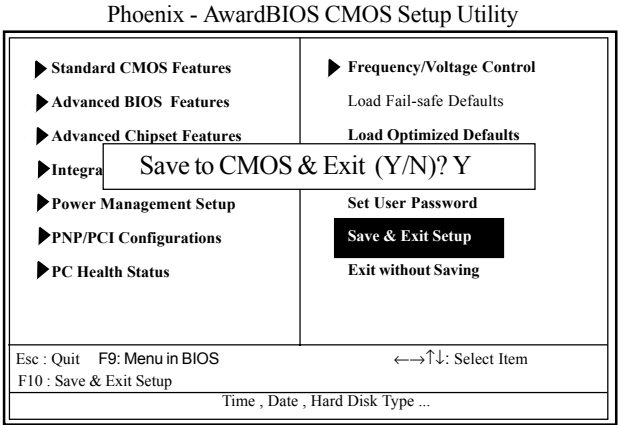

Typing “Y” will quit the Setup Utility and save the user setup value to RTC CMOS RAM.

Typing “N” will return to the Setup Utility.



# Chapter 3

## Drivers & Utilities

### 3. Drivers & Utilities

There are motherboard drivers and utilities included in the disc attached in this motherboard package. You don't have to install all of them for booting your system. But after you have finished the hardware installation, you have to install an operation system (such as windows XP) before you are able to install any drivers or utilities.

**Note: Please be aware of the different Procedures for installing drivers for Windows 98/ME/XP/2000 .**

#### 3.1 Auto-run Menu

You can use the auto-run menu in the driver CD attached in the motherboard package. Then choose the utility or driver and select model name. The autorun starting screen looks like below:

(1) The SiS Auto-run CD Main Menu



(2) SiS DriverSetup Main Menu: Point to the "Driver" button with the mouse for SiS Drivers Setup.



(3) Click to the "Driver" button and the Drivers Setup List will appear as below:

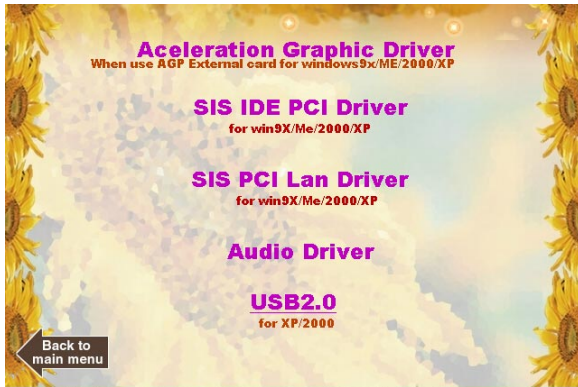

## 3.2 Install Acceleration Graphics Driver

On the SiS Drivers Setup List, mouse-click the "Acceleration Graphics Driver" bar, and the InstallShield Wizard starts to run instantly:

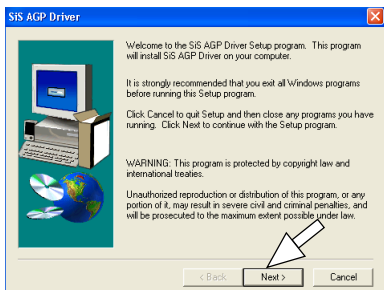

(1)  
Click "Next" button on the screen.

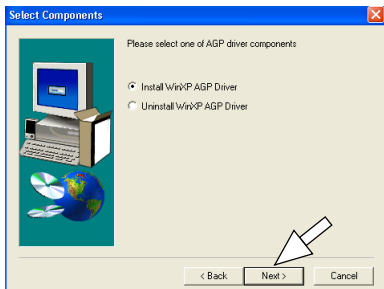

(2)  
Click "Next" button to continue.

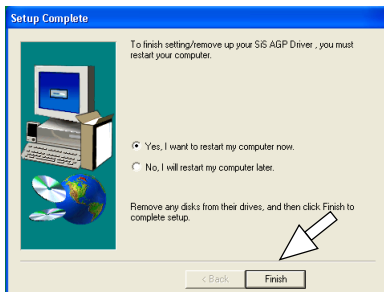

(3)  
Click "Finish" button to restart the system and complete the installation.



## 3.3 Installing SiS IDE PCI Driver

Mouse-click on the "SiS IDE PCI Driver" bar to install the SiS IDE drivers, and the InstallShield Wizard will start to run instantly.

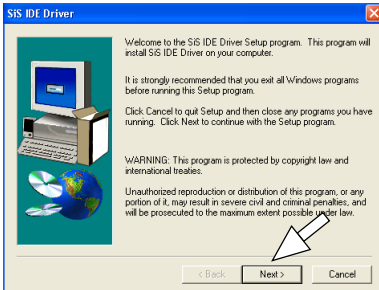

(1)  
Click "Next" button to  
continue.

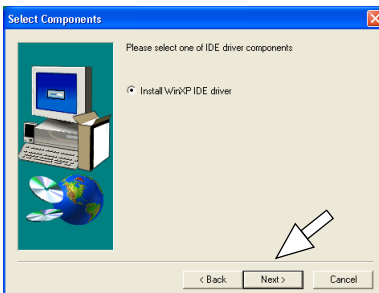

(2)  
Click "Next" button to  
continue.

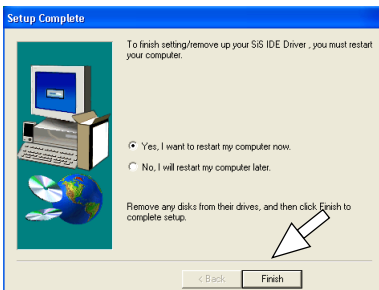

### 3.4 Install PCI LAN Driver (for 4S648N)

Mouse click the "SiS PCI LAN" bar to install the built in LAN driver. The InstallShield Wizard will start to run instantly.

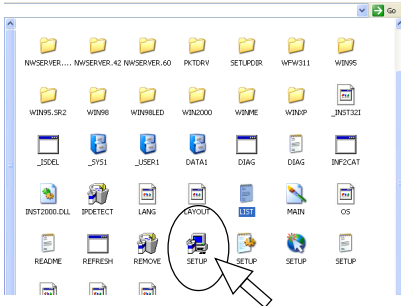

(1)  
The InstallShield Wizard will instantly find out the Setup file and expose it on the screen. Click on the "Setup" icon to start setup LAN driver.

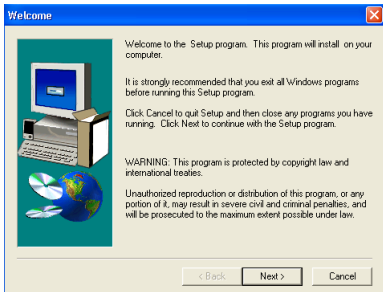

(2)  
Click "Next" button to continue.

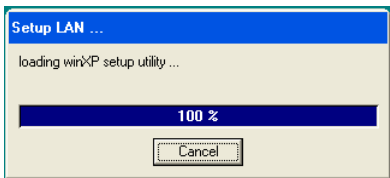

(3)  
You can see the Setup is in progress.

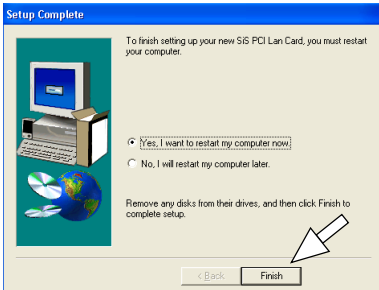

(4)  
**In a few seconds, Setup completes. Click "Finish" button to restart system and complete setup.**

## 3.4 Installing Audio Driver

Mouse click the "Audio Driver" bar on the Main Menu to set up the Audio driver. The InstallShield Wizard will start to run instantly.

### 3.4.1 Installing 6-channel Driver

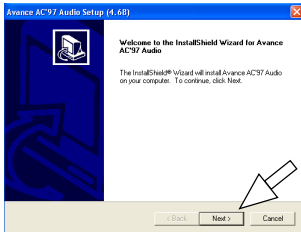

(1)  
Click "Next" button to continue.

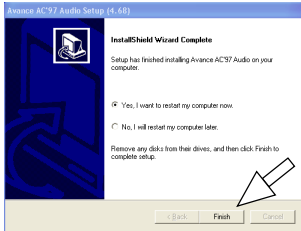

(2)  
In a few seconds, setup completes. Click the "Finish" button to restart system and complete setup.

### 3.4.2 Verifying 6-channel Driver

(1) Click the Audio Manager "Sound Effect" on the Start Screen.



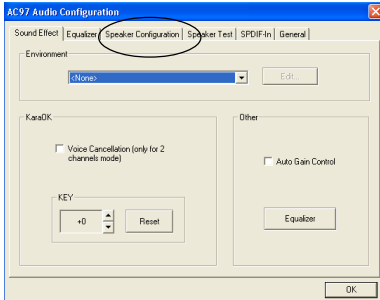

(2)  
Click "Speaker Configuration" button to configure the Audio connectors on mainboard.

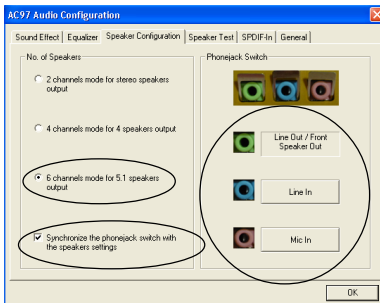

(3)  
Follow the instructions on the screen to configure the Audio connectors on board.

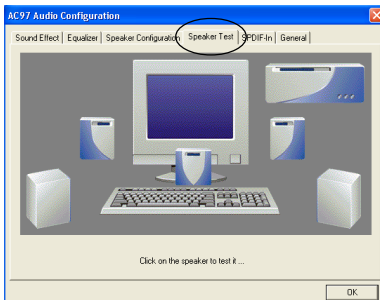

(4)  
Click "Speaker Test" button to test the 6-channel speakers.

## 3.5 Installing USB 2.0 Driver

Mouse click the "USB2.0" bar to install the SiS USB 2.0 driver. The InstallShield Wizard will start to run instantly.

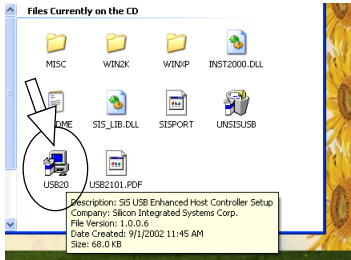

(1)  
Instantly, the "Setup files are exposed on screen. Click the "Setup" icon to install USB 2.0 driver. " item.

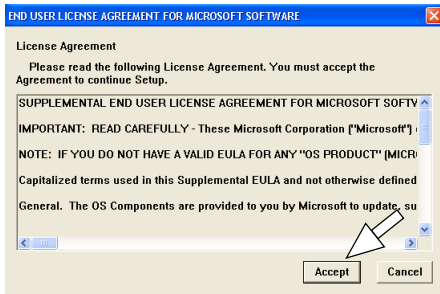

(2)  
Click the "Accept" button to agree to the License Agreement and continue.

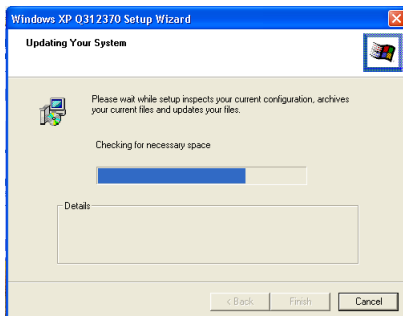

(2)  
You can see the Setup Program is updating system.

(4) In a few seconds, Setup completes. Click "Yes" button to resatart system and complete setup.

