

Specifications

200UPR Receiver

Frequency Range	UHF 63-Channel Selectable (793.750 – 805.875MHz)
Type of Reception	2 Channel Receiver
Oscillator	PLL Synthesized
RF Squelch Level	13dB μ V
Frequency Response	50Hz – 15kHz
S/N Ratio	>70dB "A" Weighted
Audio Distortion	<1% @ 1kHz
Operating Temp.	0°C – 45°C (32°F – 113°F)
MIC Out	-64dBm @ 600 Ω - 3.5mm Mini-Jack
Power Requirement	6 – 1.5V "AA" Alkaline Batteries or 12VDC @ 200mA - 6 – 8 Hours
Dimensions	105W x 105H x 35D mm (4.13W x 4.13H x 1.38D inches)
Weight	Approx. 490g Including Battery (17.28oz)

10BT Transmitter

Frequency Range	UHF 63-Channel Selectable (793.750 – 805.875MHz)
Oscillator	PLL Synthesized
RF Power	10mW (30mW Max.)
Frequency Response	50Hz – 15kHz
Max. Deviation	\pm 75kHz @ 1kHz Modulation, MIC Input -11dBm
S/N Ratio	>70dB "A" Weighted
Audio Distortion	<1% @ 1kHz
MIC Sensitivity	\pm 40kHz @ -22dBm MIC Input (0dBm+0.775V) - 3.5mm Mini Jack
Operating Temp.	0°C – 50°C (32°F – 122°F)
Power Requirement	1 – 9V Alkaline Battery - 6 – 8 Hour
Dimensions	62W x 100H x 22D mm (2.44W x 3.94H x 0.87D inches)
Weight	Approx. 120g Including Battery (4.23oz)

10HT Transmitter

Frequency Range	UHF 63-Channel Selectable (793.750 – 805.875MHz)
Oscillator	PLL Synthesized
RF Power	10mW (30mW Max.)
Frequency Response	50Hz – 12kHz
Max. Deviation	\pm 75kHz @ 1kHz Modulation, MIC Input -11dBm
S/N Ratio	>70dB "A" Weighted
Audio Distortion	<1% @ 1kHz
MIC Element	ECM
MIC Sensitivity	\pm 5kHz @ -46dBm (0dBm+0.775V)
Operating Temp.	0°C – 50°C (32°F – 122°F)
Power Requirement	2 – 1.5V "AA" Alkaline Batteries – 8-10 Hours
Dimensions	230H x \varnothing 44D mm (9.05H x 1.73D inches)
Weight	Approx. 130g Including Batteries (4.58oz)

51XT Transmitter

Frequency Range	UHF 63-Channel Selectable (793.750 – 805.875MHz)
Antenna	Internal Antenna
Pre-emphasis	50 ms
MAX Input Level	-7dBm
Microphone Unit	Dynamic Microphones
RF Output Power	15mW (50mW MAX)
Input Impedance	6K
Audio Adj Range	-63dBm ~ -18dBm
Battery	1-9V – 6-8 Hours
Dimensions	40 x 40 x 99(L) mm (1.57 x 1.57 x 3.9 inches)
Weight	152g without battery (5.4oz)

Due to constant improvements, specifications are subject to change without notice.

Azden Corporation, 147 New Hyde Park Road, P.O. Box 10, Franklin Square, NY 11010
vox - 516.328.7500 • fax - 516.328.7506 • email - azdenus@azdencorp.com

200UPR RECEIVER 200ULT • 200ULH • 200ULX SYSTEMS User's Guide

200UPR • 10BT • 10HT • 51XT ON-CAMERA UHF WIRELESS MICROPHONE SYSTEM



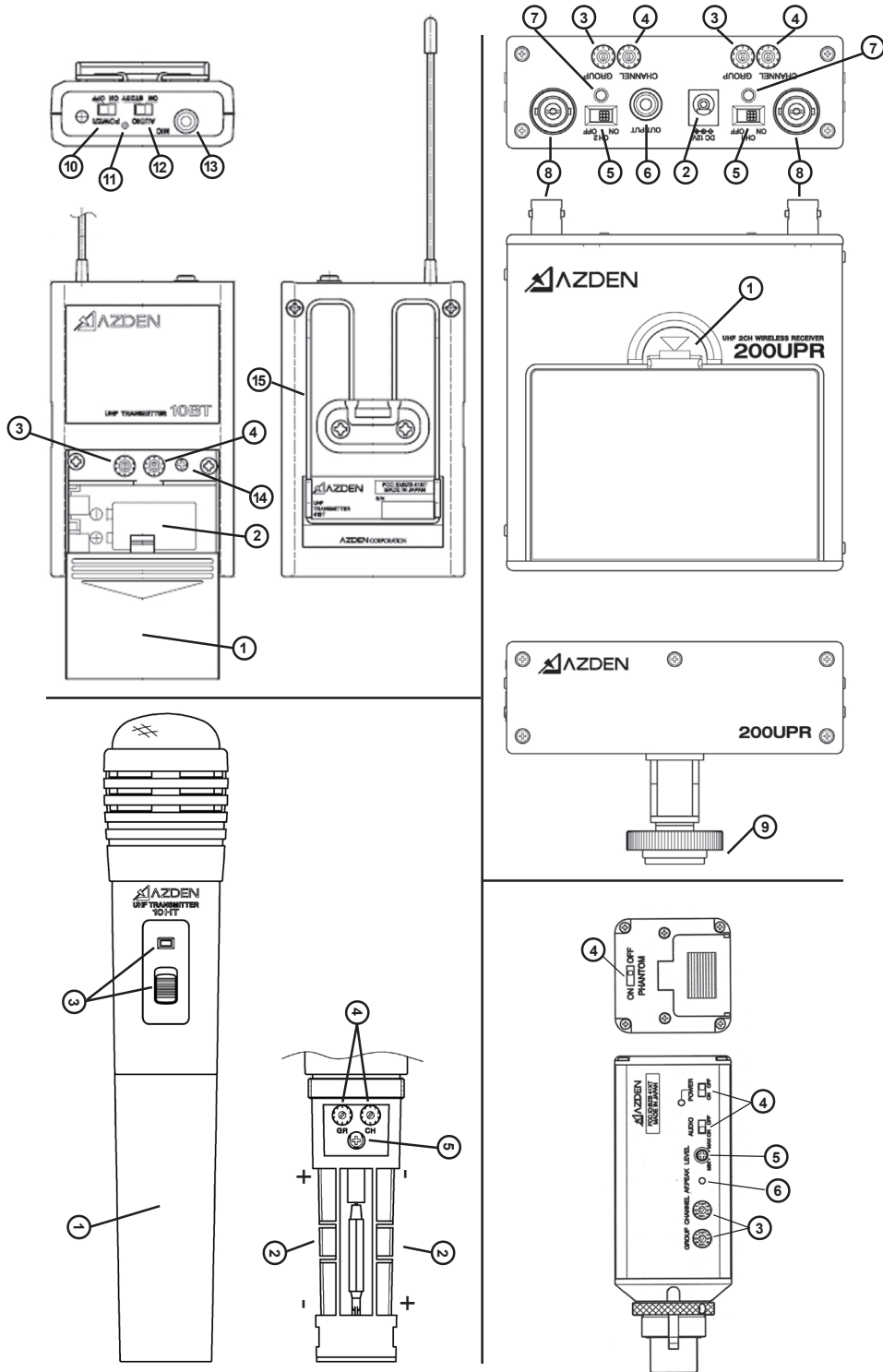

UHF FREQUENCY CHART

GRP	CHANNEL								
	0	1	2	3	4	5	6	7	8
0	794.500	795.750	797.750	798.000	799.500	800.500	802.375	804.7850	805.875
1	794.375	795.625	797.625	797.875	799.375	800.375	802.250	804.625	805.750
2	793.750	795.000	797.000	797.250	798.750	799.750	801.625	804.000	805.125
3	794.250	795.500	797.500	797.750	799.250	800.250	802.125	804.500	805.625
4	794.125	795.375	797.375	797.625	799.125	800.125	802.000	804.375	805.500
5	794.000	795.250	797.250	797.500	799.000	800.000	801.875	804.250	805.375
6	793.875	795.125	797.125	797.375	798.875	799.875	801.750	804.125	805.250

Important information

Licensing of this, or any Azden wireless equipment is the user's responsibility. The ability to receive a license depends largely on the user's classification, application and frequency. Contact the appropriate agency (FCC in the US) for further information.

These devices comply with Part 15 of the FCC Rules. Operation is subject to the following two conditions: (1) These devices may not cause harmful interference, and (2) These devices must accept any interference received, including interference that may cause undesired operation.

NOTE: The manufacturer is not responsible for any radio or TV interference caused by unauthorized modifications to this equipment. Such modifications could void the user's authority to operate the equipment.

This devices and their antenna(s) must not be co-located or operated in conjunction with any other antenna or transmitter.

200UPR Receiver

Mount the receiver to your camera using either the supplied hot-shoe mount (9). Connect the appropriate output cable to the receiver and to the microphone input(s) on your video camera. Switch one or both channels of the 200UPR to "ON" and the LED(s) should turn *red*. If either does not light, check the battery. When the 200UPR receives a signal the LED for that channel will turn *green*.

10BT Bodypack Transmitter

Plug in the supplied lapel microphone and clip it to your subject. The microphone should be placed 4-12 inches from your subject's mouth. Clip the transmitter to a belt using the supplied belt-clip (15) or place it in a pocket. Switch the transmitter Power and Audio to "ON". The LED should light *green*. If it does not, check the battery. Have someone speak into the microphone as you monitor the sound through the camera's monitor output. If the sound is distorted lower the input gain on the transmitter. If there is not enough volume raise the input gain on the transmitter.

10HT Handheld Transmitter

Switch the transmitter to "ON". The LED should light *green*. If it does not, check the batteries. If it glows *red* it is time to replace the batteries. Have someone speak into the microphone as you monitor the sound through the camera's monitor output. If the sound is distorted lower the gain on the transmitter. If there is not enough volume raise the gain on the transmitter.

51XT Plug-In Transmitter

Switch the transmitter to "ON". The LED should light *green*. If it does not, check the battery. Have someone speak into the microphone as you monitor the sound through the camera's monitor output. If the sound is distorted lower the gain on the transmitter. If there is not enough volume raise the gain on the transmitter.

Thank you for purchasing Azden's 200UPR or 200ULT/ULH/ULX wireless system, which consists of the 200UPR receiver, 10BT transmitter and EX-503 lapel microphone, the 10HT transmitter or the 51XT Plug-in transmitter. This equipment is designed primarily for video cameras but is usable with most electronic components having a microphone level input. The 200UPR allows you to "receive" audio from two different transmitters simultaneously.

RECEIVER (200UPR)

(1-2) Power:

Remove the battery compartment lid (1) and insert six fresh Alkaline "AA" batteries into the compartment. Make sure the battery polarity is correct as marked inside the battery compartment. The receiver can also be powered by an external 12VDC supply that provides 200mA (2). Follow the markings on the receiver for proper polarity.

(3-4) Frequency select (one "set" for each channel):

With the frequency group dial on the left (3) you can select any of seven frequency groups (numbered from 0-6). With the frequency channel dial on the right (4) you can select any of nine frequency channels (numbered 0-8).

(5) Power (one switch for each channel)

Switches the receiver "On" or "Off".

(6) Mic Out jack

The 200UPR is supplied with both a mini-to-mini (3-conductor-to-3-conductor) cable and a mini-to-dual XLR cable. Which cable you use depends on the input connector(s) on your camera.

(7) LED indicator (one for each channel)

The LED turns *red* when the receiver is switched "On" and *green* when receiving a signal from the transmitter.

(8) Antennas

Attach both BNC connector antennas by pressing down and rotating clockwise. The antennas can be adjusted so that they are vertical when in use.

BODYPACK TRANSMITTER (10BT)

(1) Remove the battery compartment lid by sliding it down. Insert one fresh alkaline 9V battery (2) into the compartment. Make sure the battery polarity is correct as marked inside the battery compartment.

In addition to the battery, inside the battery compartment you will find the following:

(3-4) Frequency select

With the frequency group dial on the left (3) you can select any of seven frequency groups (numbered from 0-6). With the frequency channel dial on the right (4) you can select any of nine frequency channels (numbered 0-8).

(10 and 12) Power and Standby switches

The power "ON" and "OFF" switch (10) enables and disables all transmitter functions while the Audio switch (12) "ON" and "Standby" positions turn the audio off and on. Switching the transmitter to "Standby" will cause the receiver to mute. This allows the microphone to be handled with no noise.

(11) The LED Indicator turns *green* when the Power is turned "ON". This LED will also turn *red* to indicate that battery level is low and the battery must be changed.

(13) The MIC jack accepts a 3.5mm jack from a microphone such as the supplied EX-503. Other lavalier and/or headset microphones can also be used.

(14) The Audio input Level Control enables you to adjust the input level of the microphone. Turn clockwise to increase, or counterclockwise to decrease the input level. A small screwdriver is supplied to make these adjustments. The level control is factory-preset in the center position.

HANDHELD TRANSMITTER (10HT)

(1) Remove the battery compartment cover by rotating it counterclockwise and sliding it down.

(2) Insert one fresh alkaline 1.5 V battery into each side of the battery compartment. Make sure the battery polarity is correct as marked inside the battery compartment.

(3) Power Switch and LED

The power "ON" and "OFF" switch (3) enables and disables all transmitter functions. Sliding it toward the LED turns the transmitter ON. The LED will turn *green* when the batteries are fresh and *red* when it is time to replace the batteries. Sliding the switch away from the LED turns the transmitter OFF.

In addition to the batteries, inside the battery compartment you will find the following:

(4) Frequency select

With the frequency group dial on the left you can select any of seven frequency groups (numbered from 0-6). With the frequency channel dial on the right you can select any of nine frequency channels (numbered 0-8).

(5) The Audio Level Control enables you to adjust the overall level of the microphone. Turn clockwise to increase, or counterclockwise to decrease the volume level. A small screwdriver is supplied to make these adjustments. The level control is factory-preset in the center position.

51XT plug-in XLR transmitter

(1) Open the battery compartment lid by sliding it down and raising it

(2) Insert one fresh alkaline 9-volt battery into the compartment. Make sure battery polarity is correct.

(3) Frequency select

The group knob allows you to select any of seven frequency groups (numbered from 0-6). The channel knob allows you to select any of nine frequency channels (numbered from 0-8) within the selected group.

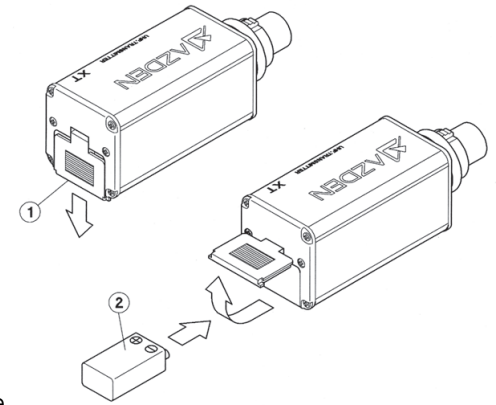

(4) Power and Audio switches

The power "On/Off" switch enables and disables all transmitter functions while the Audio "On/Off" switch turns just the transmitter's Audio signal on and off. Switching the Audio to "Off" will cause the receiver to mute using the tone squelch circuitry in the receiver. This allows the microphone to be handled with no noise. The "Phantom" switch allows the 51XT to provide 5V to power electret condenser microphones.

(5) Audio input LEVEL control

This enables you to adjust the input level of the microphone. Turn clockwise to increase, or counterclockwise to decrease the input level. A small screwdriver is supplied to make adjustments.

(6) LED INDICATORS

The POWER LED turns green when power is turned "On" or red if battery level is low. If this LED lights up red replace the battery. The AF PEAK LED lights up if the input level is set to high, indicating the onset of distortion. Lower the input level so that the AF PEAK LED lights only occasionally.

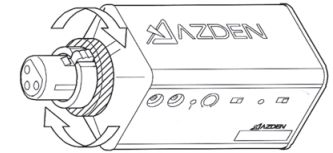

To plug the 51XT onto a microphone (low impedance with XRL connector) first make certain the locking-ring is turned fully up (rotate counterclockwise). Then plug the 51XT fully into the microphones XLR connector and tighten by rotating the ring fully down (clockwise).

Operating the system

Because this is a frequency agile system, you have to choose the frequency for both the transmitter and receiver via the group and channel dials (3 and 4). We cannot stress enough that the transmitter and receiver pair **MUST BE SET TO THE SAME GROUP and CHANNEL NUMBER**. Additionally, multiple systems used in the same location should be on the same group number but on different channel numbers. (See below for example) **ALWAYS CHECK THAT THE FREQUENCY YOU'VE CHOSEN IS CLEAR PRIOR TO USING THE SYSTEM.**

Finally, if you need to change the group or channel number you must shut off both the transmitter and receiver before making a change. When the units are turned "On" the frequency is locked and will not change.

When operating multiple systems all receivers and transmitters must be on the same group.

Example: 4 systems operating simultaneously.

	System #1		System #2		System #3		System #4	
	Group	Channel	Group	Channel	Group	Channel	Group	Channel
Receivers	2	4	2	5	2	6	2	7
Transmitters	2	4	2	5	2	6	2	7

To change the frequency of a transmitter/receiver pair that is already on YOU MUST TURN BOTH THE TRANSMITTER AND RECEIVER "OFF" FIRST!